



PROSOCO®

R•Guard®

AIR & WATER BARRIERS

You. Us. The project.

Installation Guidelines

800 255 4255 | PROSOCO.COM

Sheathing Wall Construction

- Sheathing Wall Seam **S1.1**.....4
- Inside/Outside Wall Corners **S2.1**.....5
- Pipe and Mechanical Penetrations **S3.1**.....6
- Rough Opening on Sheathing Wall One Product **S4.1A**.....7
- Rough Opening on Sheathing Wall Two Products **S4.1B**.....8
- Window Head Flashing **S5.1**.....9
- Sealing Window Flanges **S6.1**.....10
- Interior Air and Water Seal **S7.1**.....11
- Roof-To-Wall Transition - Parapet Wall Face **S8.1**.....12
- Roof-To-Wall Transition - Wall Cap to Roof **S9.1**.....13
- Termination at Grade - Stucco **S10.1**.....14
- Rough Opening Integration with Building Wrap **S11.1**.....15
- Deflection joint 1 Inch and Smaller **S12.1A**.....16
- Deflection joint greater than 1 Inch **S12.1B**.....17
- Deflection joint Corner Condition Greater than 1 Inch **S12.1C**.....18
- Rough Opening with FastFlash and building Wrap **S13.1**.....19
- Vertical Expansion joint **S14.1**.....20
- Vertical Expansion at Disimilar Substrate > 1" wide **S14.2**.....21
- Overlap/Splice Joint of SureSpan EX **S14.3**.....22
- Corner Overlap/Butt Joint of SureSpan EX **S14.4**.....23
- Joint Intersection SureSpan EX **S14.5**.....24

CMU/CIP Wall Construction

- CMU/CIP Concrete Rough Opening **C1.1**.....25
- Pipe and Mechanical Penetrations **C2.1**.....26
- Wall-to-Roof Transition - Parapet to Roof Plane **C3.1**.....27
- CMU/CIP Concrete Arched Window Rough Opening **C4.1**.....28
- Interior Air and Water Seal **C5.1**.....29
- Sliding Glass Door **C6.1**.....30

SS Thru Wall Flashing

- Flashing Corner Units and End Dams **F1.1**.....31
- Outside Corner Detail **F1.1A**.....32
- Inside Corner Detail **F1.1B**.....33
- SS Thru Wall Accessories **F1.1C**.....34
- Flashing Transition - Base of Wall **F2.1**.....35
- Flashing Transition - Shelf Angle with Termination Bar **F3.1**.....36
- Window Head Detail SS Thru Wall Flashing & Termination Bar **F4.1**.....37

Reap the many benefits of R-Guard air and water barrier system



Offers superior durability

- Withstands extreme weather conditions
- Makes rough openings air- and water-tight
- Saves money, time and energy
- Can be applied rain or shine
- Color-coded components take the guesswork out of application
- Vapor-permeable
- Meets many sustainable performance standards
- Helps walls dry out

Visit prosoco.com for additional drawings.

©PROSOCO 2016

R-Guard

Sheathing Wall Seam - S1.1

AIR & WATER BARRIERS

Sheathing Wall Construction with gypsum, plywood or OSB sheathing.

Spot all over-driven, or improperly installed fasteners with **FastFlash** or **Joint & Seam Filler**.

Apply a thick bead of **FastFlash** or **Joint & Seam Filler** to all sheathing joints.

Use a dry joint knife or trowel to spread 1 inch beyond the seam on each side to a thickness of 20-30 mils.

Follow sheathing manufacturer recommendations to repair joints or

gaps greater than 1 inch.

Apply the selected R-Guard air and water-resistive barrier over the prepared sheathing wall.

Step One

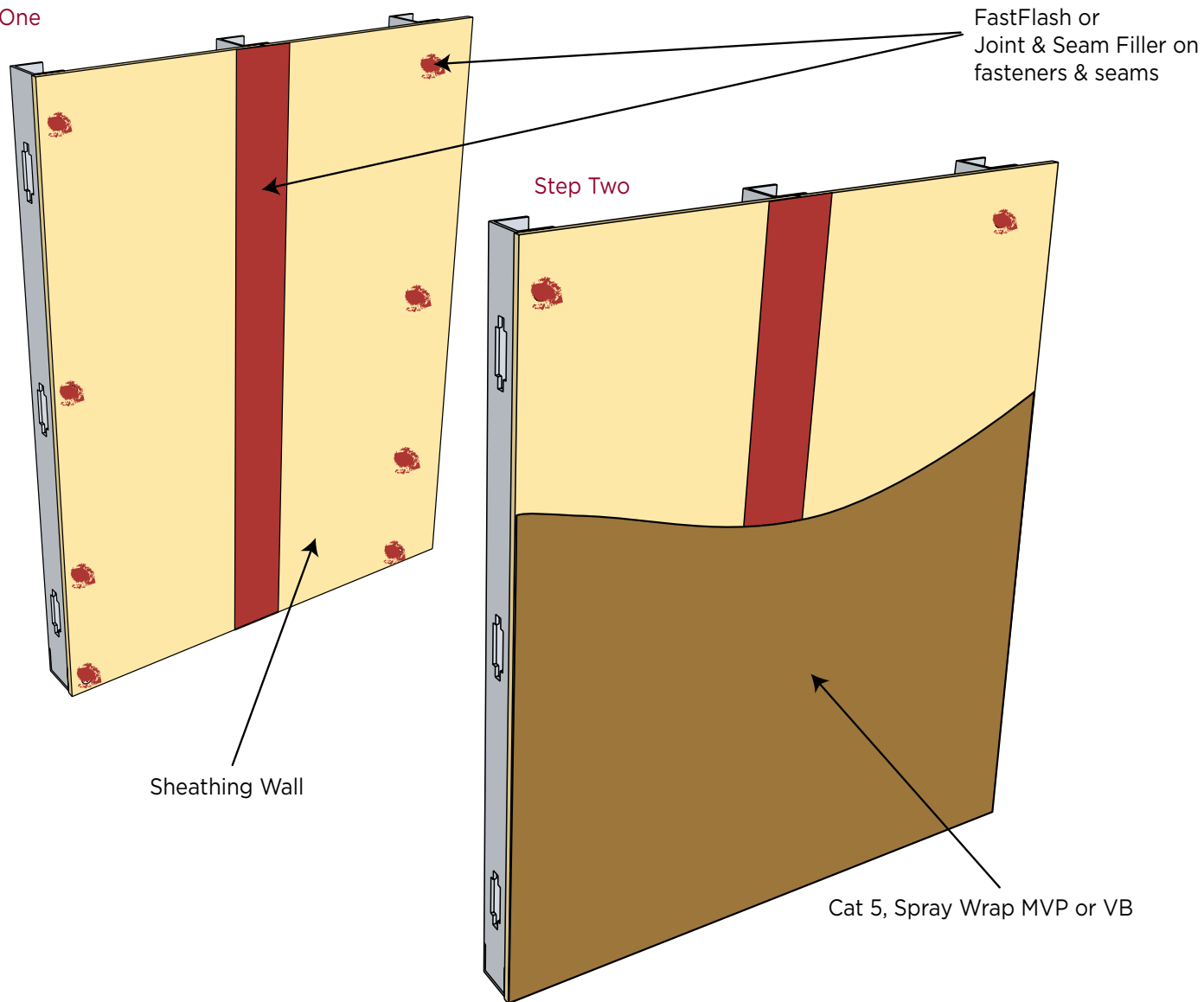

R-Guard

Inside/Outside Wall Corners - S2.1

AIR & WATER BARRIERS

Sheathing Wall Construction with gypsum, plywood or OSB sheathing.

Consolidate and seal the raw, cut gypsum board edges within the inside/outside wall corners by brushing on a thin uniform coat of **PorousPrep**.

Apply **FastFlash** or **Joint & Seam Filler** to all inside corners, fill outside corner joint with **Joint & Seam Filler**. Use a dry joint knife or trowel to spread 1 inch beyond seam and outer cut edge to a thickness of 20-30 mils.

Apply the selected R-Guard air and water-resistive barrier over the prepared sheathing wall.

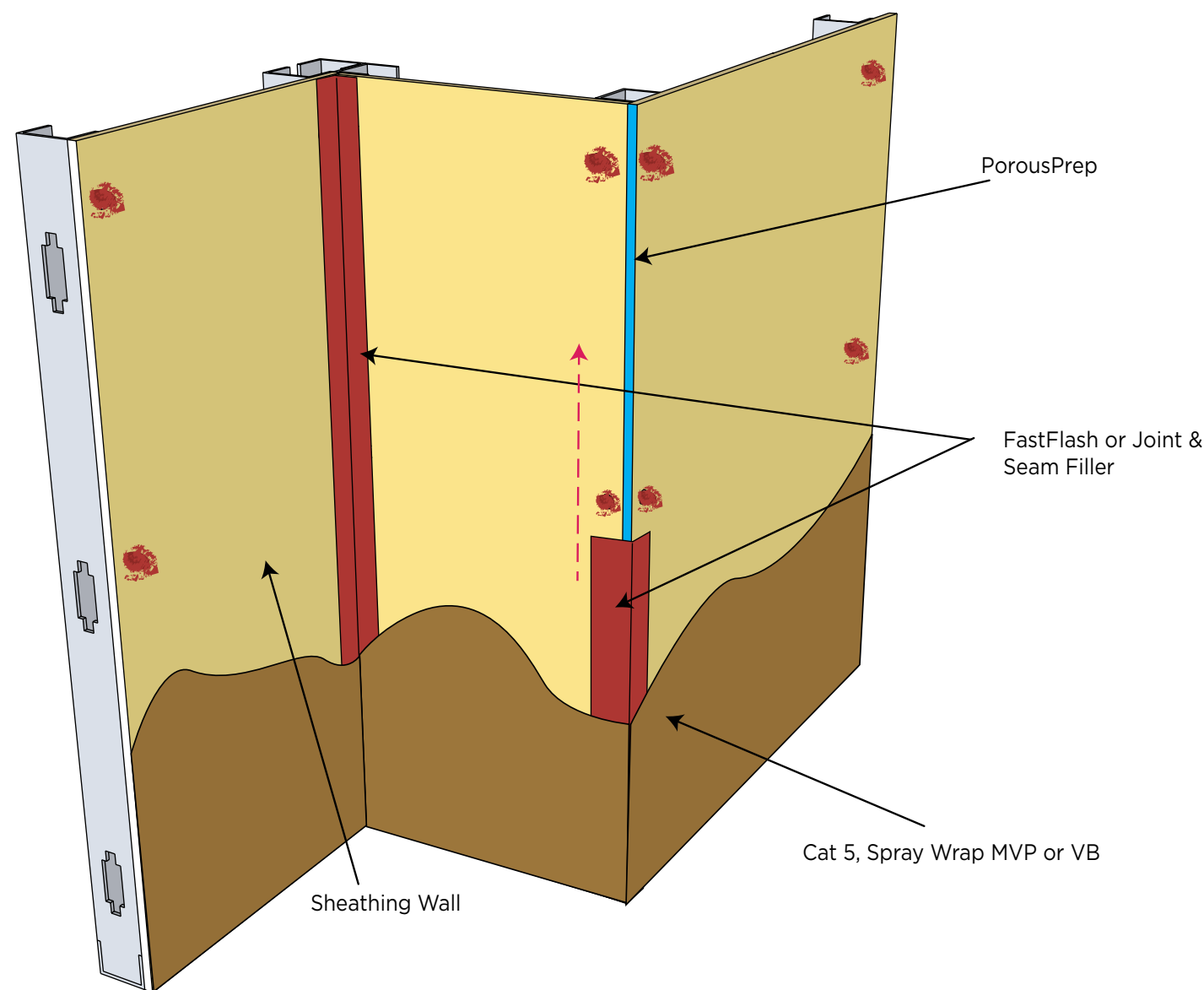

R-Guard

Pipe & Mechanical Penetrations - S3.1

AIR & WATER BARRIERS

Sheathing Wall Construction with gypsum, plywood or OSB sheathing.

Mechanically secure loose penetrations at the interior of the wall before detailing. Install non-gassing polyethylene foam backer rod backed by spray foam around electrical fixtures, conduit or plumbing to form a back dam.

Apply a thick bead of **FastFlash** or **Joint & Seam Filler** around the penetration. Use a dry trowel or spatula to tool and seal the joint. Create a joint profile that directs bulk water away from the opening.

Apply the selected R-Guard air and water-resistive barrier over the prepared sheathing. Use a chipper brush to cover the **FastFlash** or **Joint & Seam Filler** that surrounds any mechanical penetrations with selected barrier membrane. Apply sufficient product to cover the entire face of the structural wall and all exposed **FastFlash** or **Joint & Seam Filler**.

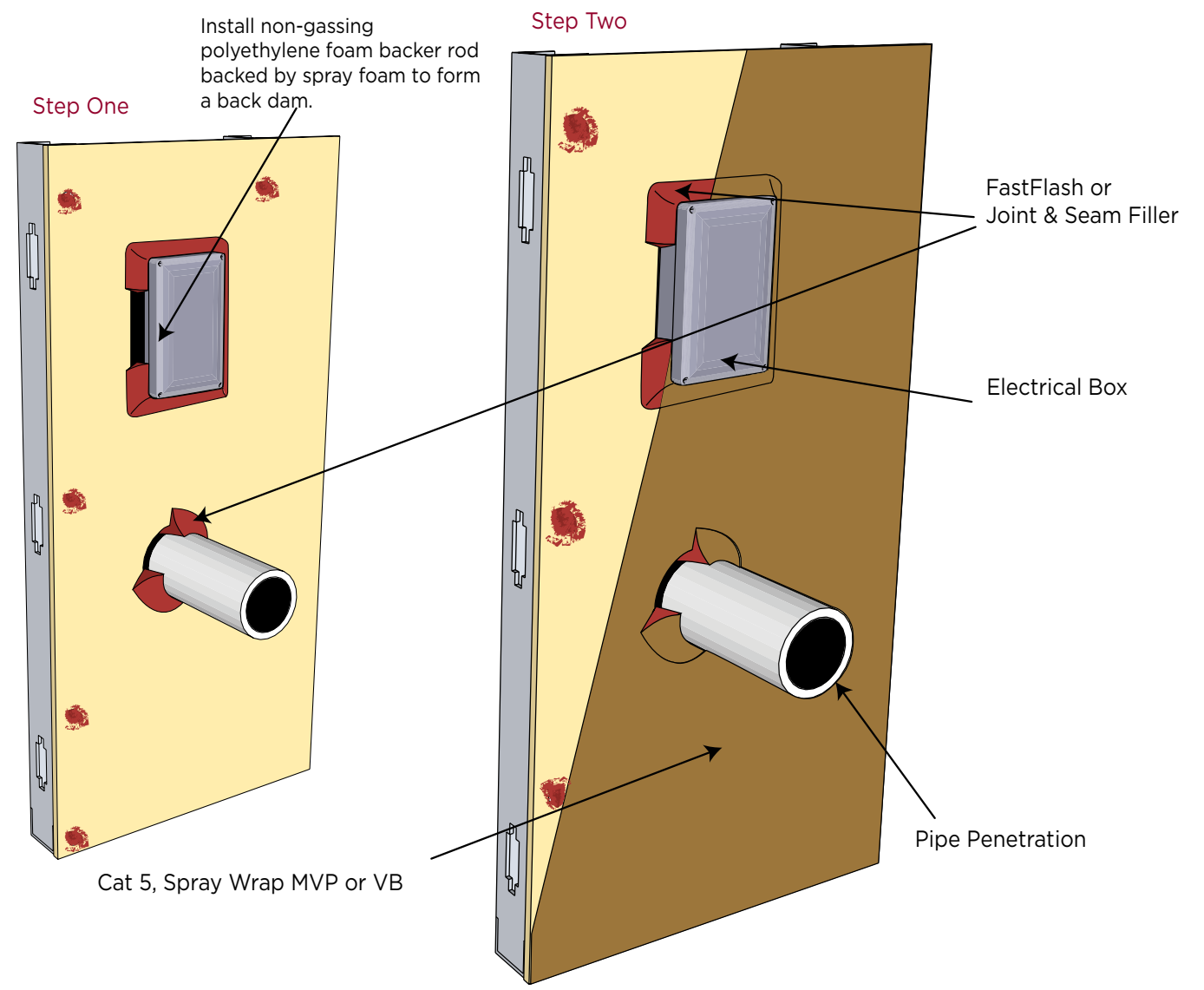

R-Guard

Rough Opening Using One Product - S4.1A

AIR & WATER BARRIERS

Sheathing Wall Construction with gypsum, plywood or OSB sheathing.

Apply a thick bead of **FastFlash** to all inside corners, joints and seams, and framing surfaces within the rough opening at 12-15 mils.

Apply a thick bead of **FastFlash** over the framing inside the rough opening and the structural wall surrounding the rough opening. Use a dry joint knife, trowel or chipper brush to spread the wet product to create a seamless flashing membrane which protects the rough opening and extends 4-6 inches over the face of the structural wall. When using a flanged window, extend **FastFlash** 2 inches beyond the edge of the window flange. Apply additional

FastFlash as needed to create an opaque, monolithic flashing membrane free of voids or pinholes.

Apply the selected R-Guard air and water-resistive barrier over the prepared sheathing. Apply sufficient product to cover the entire face of the structural wall.

When stud framing is used in lieu of track, cover knockout with breakmetal and seal edges with **FastFlash** (see insert below).

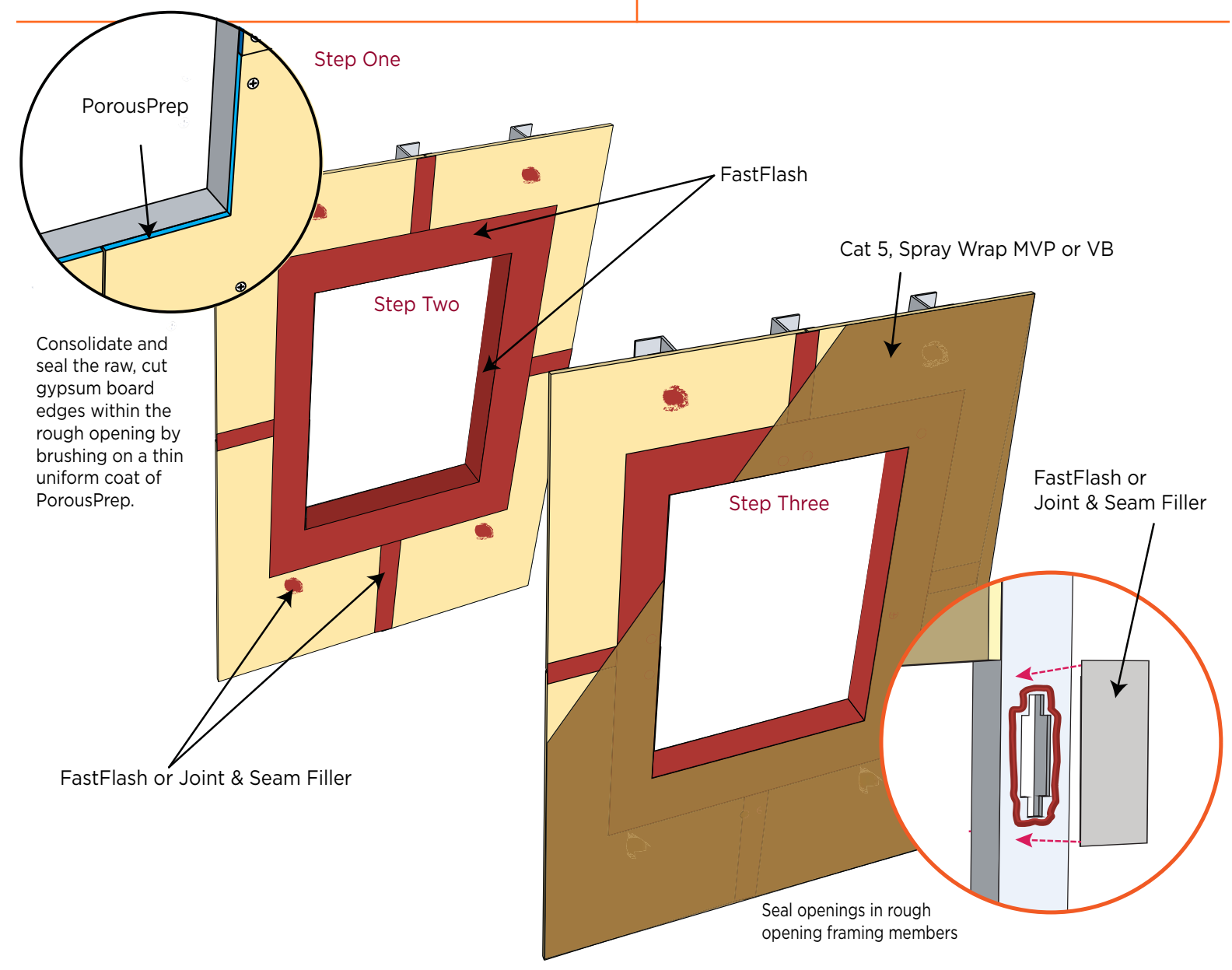

R-Guard

Rough Opening Using Two Products - S4.1B

AIR & WATER BARRIERS

Sheathing Wall Construction with gypsum, plywood or OSB sheathing.

Apply a thick bead of **Joint & Seam Filler** to all inside corners, joints and seams within the rough opening. Use a dry joint knife or trowel to spread 1 inch beyond the seam on each side to a thickness of 20-30 mils.

Apply a thick bead of **FastFlash** over the framing inside the rough opening and the structural wall surrounding the rough opening. Use a dry joint knife, trowel or chipper brush to spread the wet product to create a seamless flashing membrane which protects the rough opening and extends 4-6 inches over the face of the

structural wall. When using a flanged window, extend **FastFlash** 2 inches beyond the edge of the window flange. Apply additional **FastFlash** as needed to create an opaque, monolithic flashing membrane free of voids or pinholes.

Spray or roller apply the selected R-Guard air and water-resistive barrier over the prepared sheathing. Apply sufficient product to cover the entire face of the structural wall.

When stud framing is used in lieu of track, cover knockout with breakmetal and seal edges with **FastFlash** (see insert below).

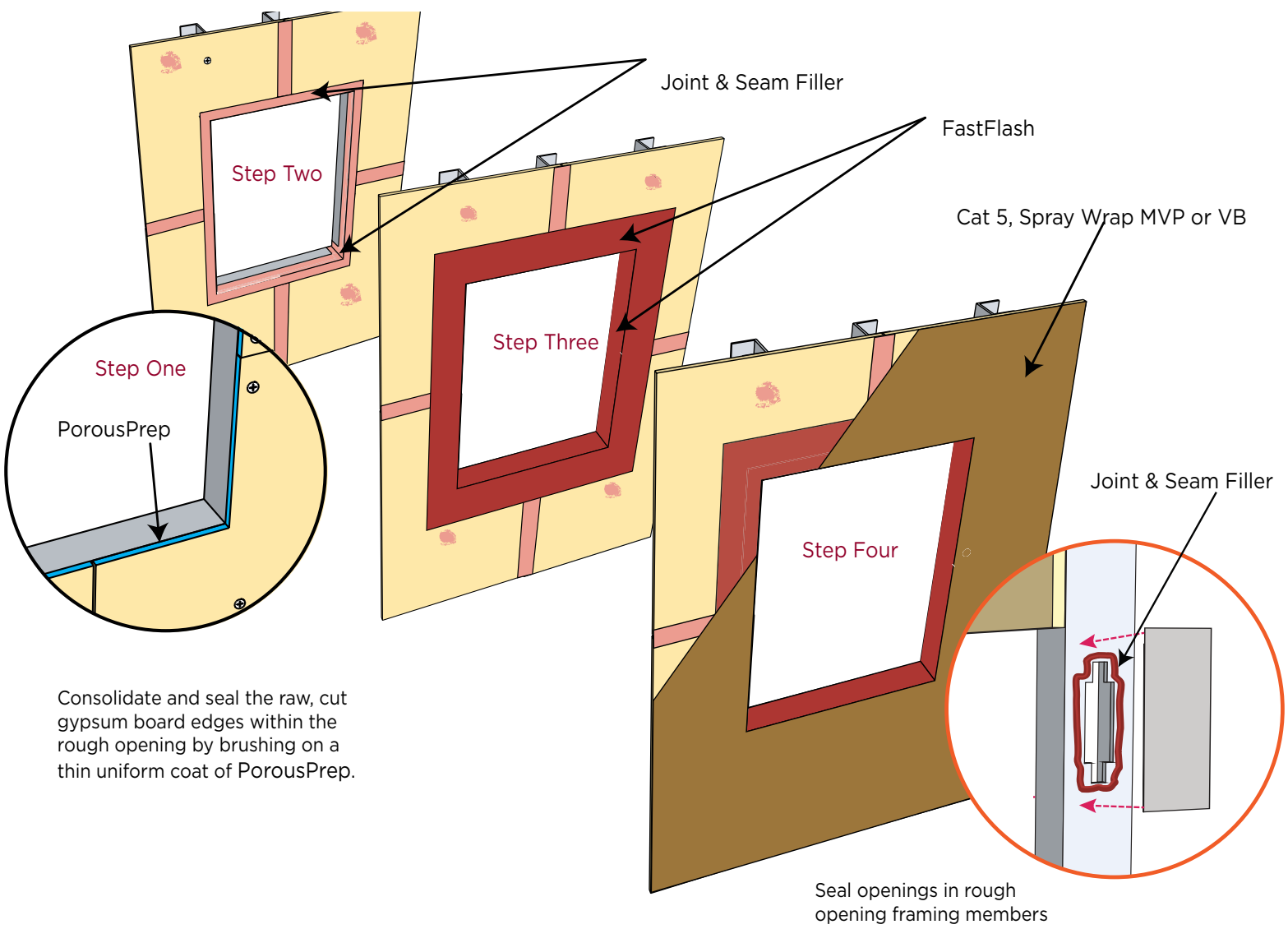

Consolidate and seal the raw, cut gypsum board edges within the rough opening by brushing on a thin uniform coat of PorousPrep.

R-Guard

Window Head Using SS ThruWall Flashing - S5.1

AIR & WATER BARRIERS

Sheathing Wall Construction with gypsum, plywood or OSB sheathing.

Install the window "plumb, level and square" into the rough opening prepared with **Joint & Seam Filler** and/or **FastFlash**.

Use **AirDam** as the interior air sealant to ensure compatibility with the treated rough opening and create a long-lasting, weather-tight seal (see S7.1).

Apply a thick bead of **FastFlash** or **Joint & Seam Filler** across the top of the rough opening. Wet-set the R-Guard **SS ThruWall** flashing. Mechanically fasten the **SS ThruWall** flashing.

Apply a bead of **FastFlash** or **Joint & Seam Filler** to the top edge of the **SS ThruWall** flashing. Use a dry trowel or spatula to tool and seal the joint. Create a profile that directs bulk water away from the joint. Allow joint to skin over.

To transition from the air- and water-resistive barrier to the **SS ThruWall** flashing, apply a bead of **FastFlash** immediately above and below the top edge of the **SS ThruWall** flashing. Use a dry joint knife or trowel to spread the wet product to create a seamless counter-flashing membrane which directs bulk water from the air- and water-resistive barrier to the **SS ThruWall** flashing. Apply additional **FastFlash** as needed to create an opaque, monolithic flashing membrane free of voids or pinholes.

Note: Trade sequencing may make wet-setting impractical and it is not required.

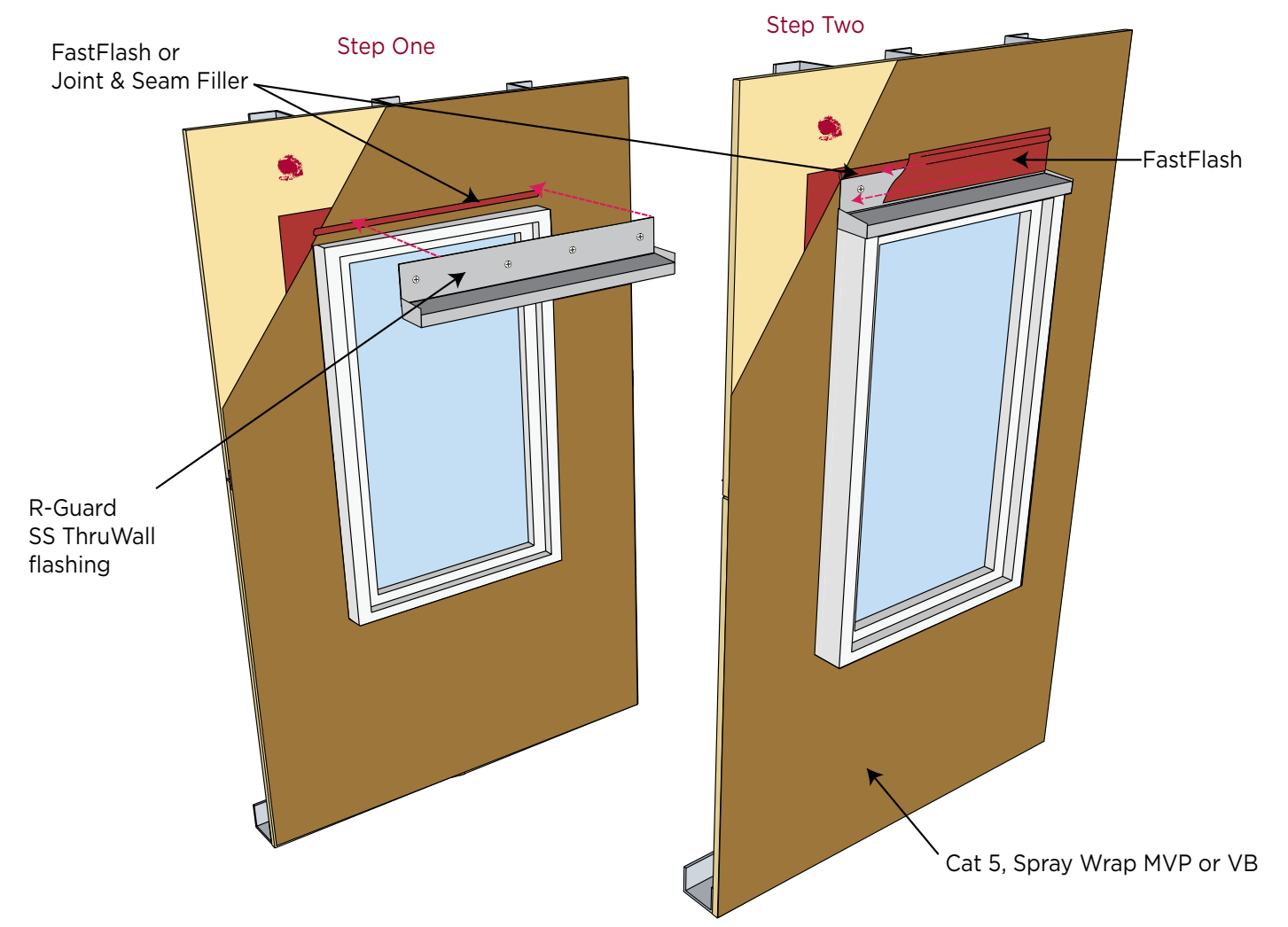

R-Guard®

Sealing Window Flange - S6.1

AIR & WATER BARRIERS

Sheathing Wall Construction with gypsum, plywood or OSB sheathing.

Install the window “plumb, level and square” into the rough opening prepared with **Joint & Seam Filler** and **FastFlash**.

If the manufacturer’s instructions say to “wet-set” the exterior window flange, install a continuous bead of **AirDam** on the back of the flange along the top (head) and sides (jambs) of the window -- making sure to leave the sill flange free of **AirDam** sealant for drainage capabilities. Place the window in the prepared rough opening. Install fasteners as directed by the window manufacturer.

Use **AirDam** as the interior air sealant to ensure compatibility with the treated rough opening and create a long-lasting, weather-tight seal.

Limit counter flashing to the top (head) and sides (jambs) of the window. Do not seal the window bottom (sill) or obstruct weeps.

To seal the window flange, apply a thick bead of **FastFlash** over the outer edge of the window flange. Apply a second thick bead over the structural wall adjacent to the window flange at the window head and jambs. Use a dry joint knife, trowel or chipper brush to spread the wet product to create a seamless membrane, directing bulk water away from the window and the rough opening. Apply additional **FastFlash** as needed to create an opaque, monolithic membrane free of voids or pinholes.

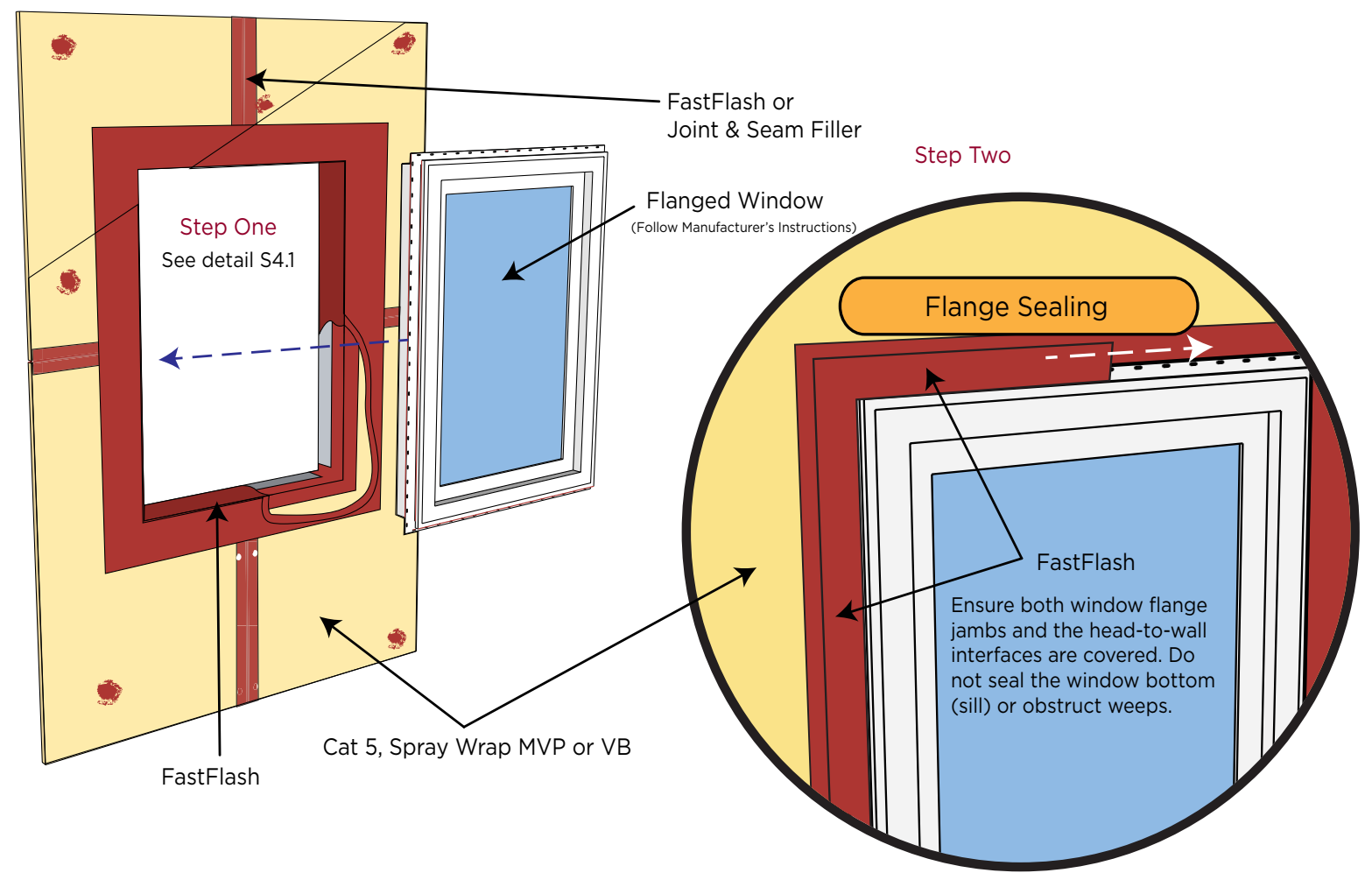

R-Guard®

Interior Air and Water Seal - S7.1

AIR & WATER BARRIERS

Sheathing Wall Construction with gypsum, plywood or OSB sheathing.

Install the window “plumb, level and square” into the prepared rough opening.

Use **AirDam** as the interior air sealant to ensure compatibility with the treated rough opening and create a long-lasting, weather-tight seal. **AirDam** prevents bulk water and moist outside air from entering, and conditioned indoor air from escaping around the window. This ties the window into the larger air and water management system, and prevents water which may collect in the window frame from entering the conditioned space.

Joint Size – Sealant depth should be one-half the width of the joint. Maximum sealant depth should be ½ inch (13 mm). Minimum sealant depth should be ¼ inch (6mm). Minimum joint width should be ¼ inch (6mm).

Joint Backing – A properly sized non-gassing polyethylene foam backer rod should compress by 25-30% when installed. Install backer rod by compressing and rolling continuously into the joint channel without stretching or puncturing.

Installation – Install a continuous bead of **AirDam** without gaps or air pockets. Tool immediately with a dry spatula to ensure complete wetting of the joint bond surface and produce a smooth, concave joint profile.

FastFlash wraps into the rough opening in the structural wall. See detail S4.1.

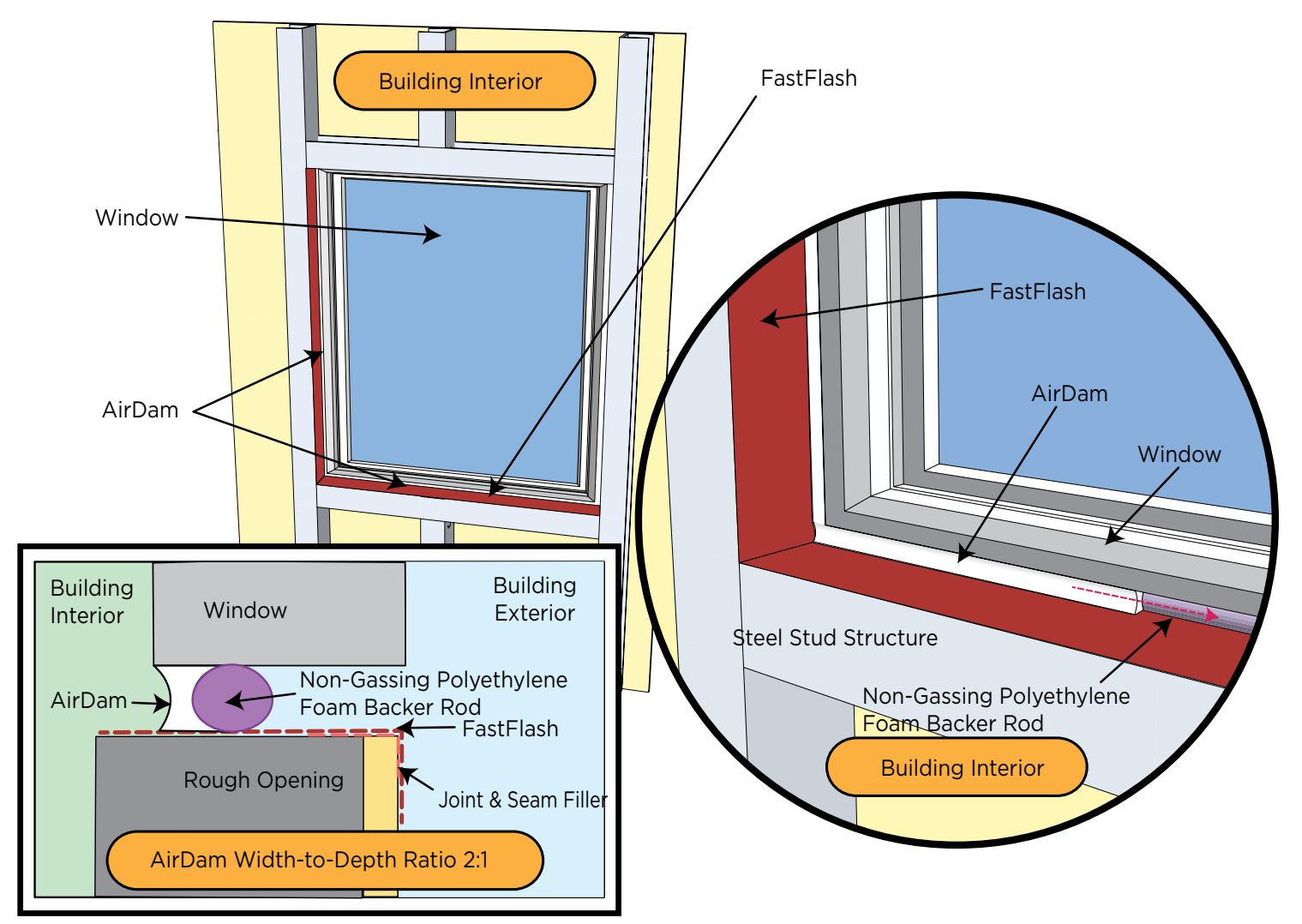

R-Guard

Roof-To-Wall Transition - Parapet Wall Face - S8.1

AIR & WATER BARRIERS

Sheathing Wall Construction with gypsum, plywood or OSB sheathing.

Consolidate and seal any raw, cut gypsum board edges by brushing or spraying on a thin uniform coat of **PorousPrep**.

Along the top edge of the non-vented parapet, apply a bead of **FastFlash** or **Joint & Seam Filler** to the seams between the back of the sheathing and the structural member, and 1 inch over the vertical face on both sides of the parapet. Spread the wet product to create a seamless transition. Allow to skin over.

Apply a thick bead of **FastFlash** or **Joint & Seam Filler** down the center of the structural member. Wet-set the wood blocking. Mechanically fasten the wood blocking. Spot the head of all fasteners that penetrate the wood blocking. Allow to skin over.

Apply a thick bead of **FastFlash** or **Joint & Seam Filler** to the joint between the wood blocking and the top of the wall. Use a dry trowel or spatula to tool and seal the joint. Create a profile that directs bulk water away from the joint. Allow to skin over.

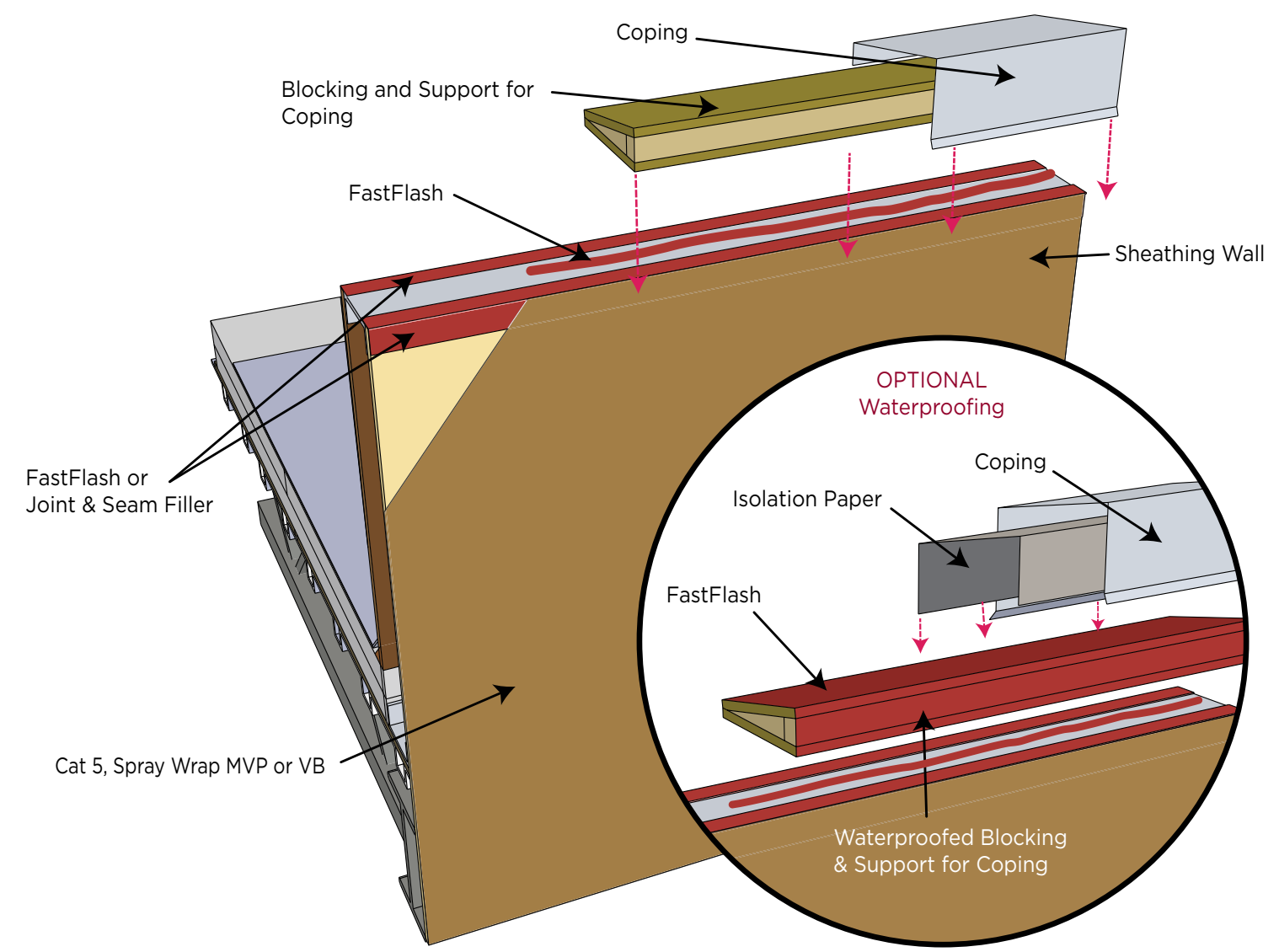

R-Guard

Roof-To-Wall Transition - Wall Cap to Roof - S9.1

AIR & WATER BARRIERS

Sheathing Wall Construction with gypsum, plywood or OSB sheathing.

Apply **FastFlash** or **Joint & Seam Filler** to non-vented parapet sheathing wall seams and roof decking seams (see detail S1.1). Apply a thick bead of **FastFlash** or **Joint & Seam Filler** to the base of the parapet sheathing wall and roof deck interface. Use a dry trowel or spatula to tool and seal the joint. Create a profile that directs bulk water away from the joint. Allow to skin over.

Roller apply **Cat 5** to the parapet sheathing wall and the roof decking to form an opaque, monolithic membrane over the sheathing and the roof deck, which is free of voids and pinholes.

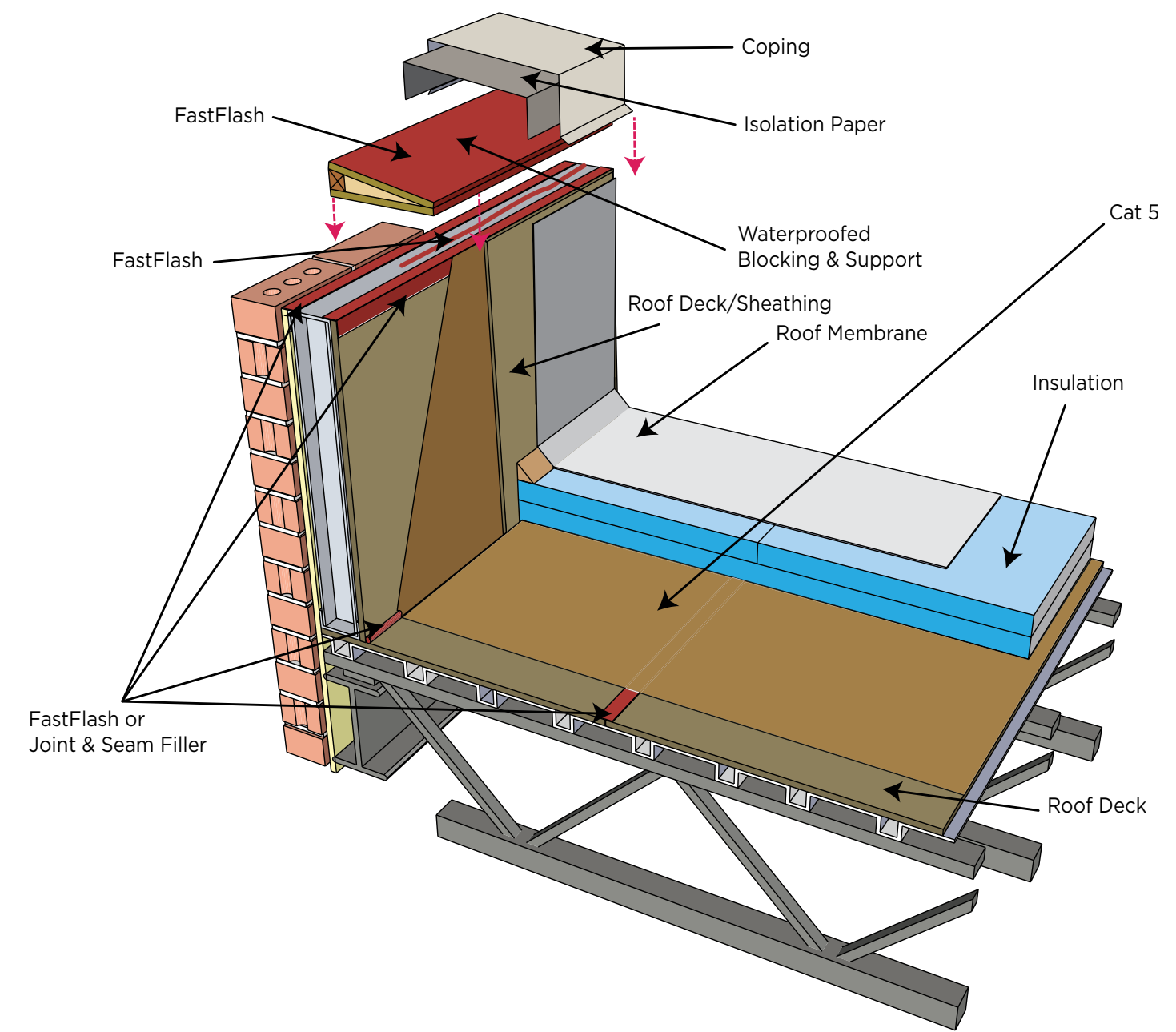

R-Guard

Termination at Grade - Stucco - S10.1

AIR & WATER BARRIERS

Sheathing Wall Construction with gypsum, plywood or OSB sheathing.

Note: Below-grade waterproofing should be in place prior to application of an R-Guard membrane. Transition interface should be cleaned prior to air barrier application.

Install non-gassing polyethylene foam backer rod (SofRod) into joint at foundation-to-wall interface. Apply enough **FastFlash** or **Joint & Seam Filler** to sufficiently fill the joint to allow for tooling of excess sealant onto the sheathing and the foundation waterproofing, approximately 2 inches on either side. DO NOT spread product beyond the flange edge of the weep screed.

Roller apply **Cat 5** over cured sealant and onto sheathing board in preparation to install weep screed. Wet-set vertical flange of weep

screed into **FastFlash** or **Joint & Seam Filler**, then secure screed with fasteners over cured **Cat 5** on sheathing board. Seal top of vertical flange with a bead of **Joint & Seam Filler** and tool smooth.

Trade sequencing may make wet-setting impractical, and it is not required.

Apply an additional coat of **Cat 5** over the **Joint & Seam Filler**, tying into the in-place **Cat 5** membrane to complete the detail.

Install paper-backed metal lath in preparation for the scratch coat application of stucco.

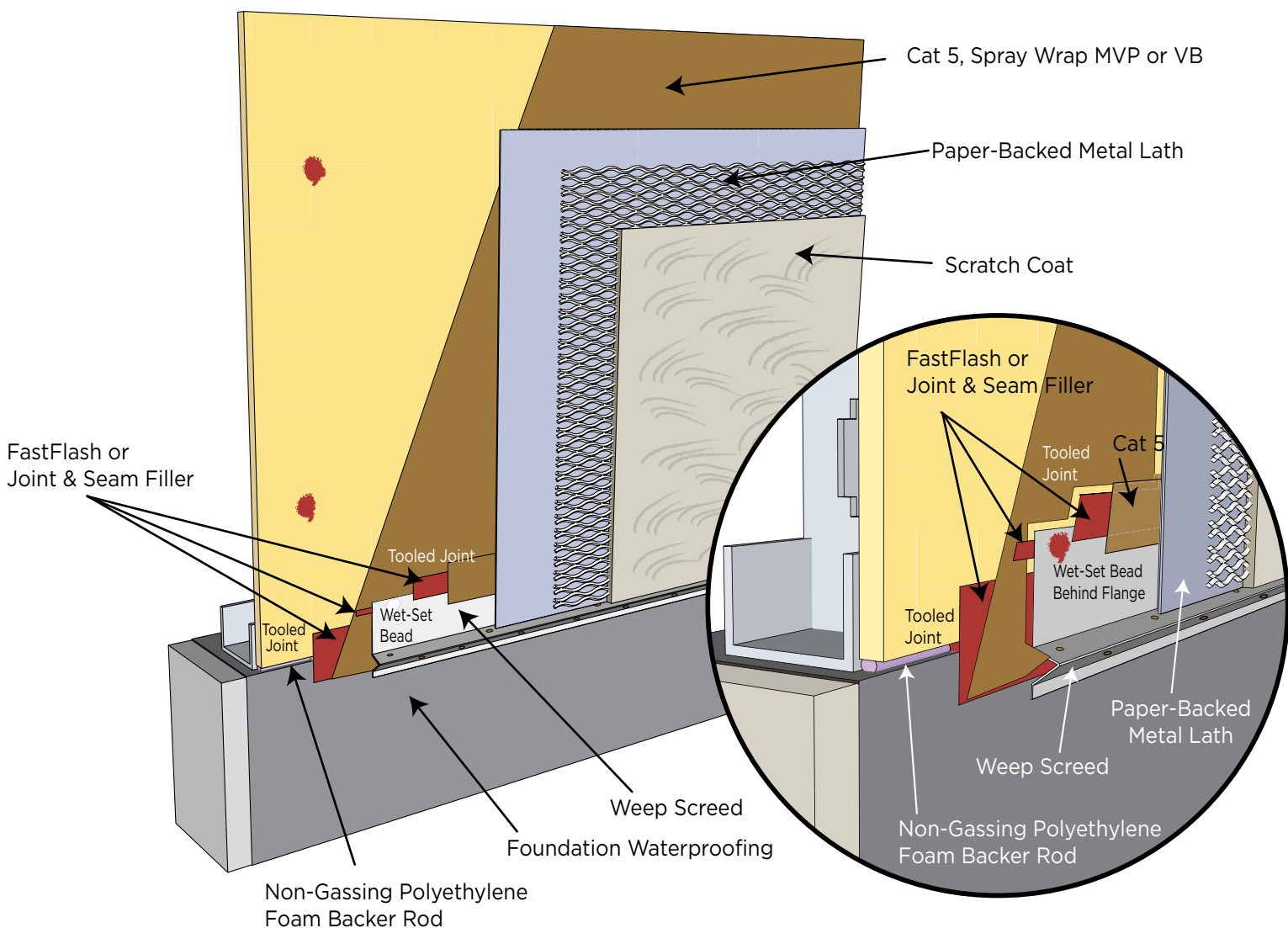

R-Guard

Rough Opening Integration with Building Wrap - S11.1

AIR & WATER BARRIERS

Sheathing Wall Construction with gypsum, plywood or OSB sheathing.

Remove the existing window, flashing and water-resistive barrier to expose the rough opening. Repair the rough opening as required.

Consolidate and seal any new, cut gypsum board edges within the rough opening by brushing on a thin uniform coat of **PorousPrep**.

Wet-set a properly sized and adhesion-compatible transition sheet, such as Moiststop PF, into the wet **FastFlash**. Apply additional **FastFlash** to the leading edge of the transition sheet.

After preparing the rough opening pursuant to S4.1A or S4.1B, use a dry joint knife, trowel or chipper brush to spread the **FastFlash** to create a seamless flashing membrane. To protect the rough opening, make sure the membrane extends 9 inches - or as necessary to reach

no less than 4-6 inches beneath any existing building wrap - over the face of the structural wall on the head and jambs.

Spread the wet product to embed that edge of the transition sheet and down over the transition sheet 2" to create a seamless flashing transition.

Shingle the transition sheet to create no less than a 6-inch lap over the existing building wrap.

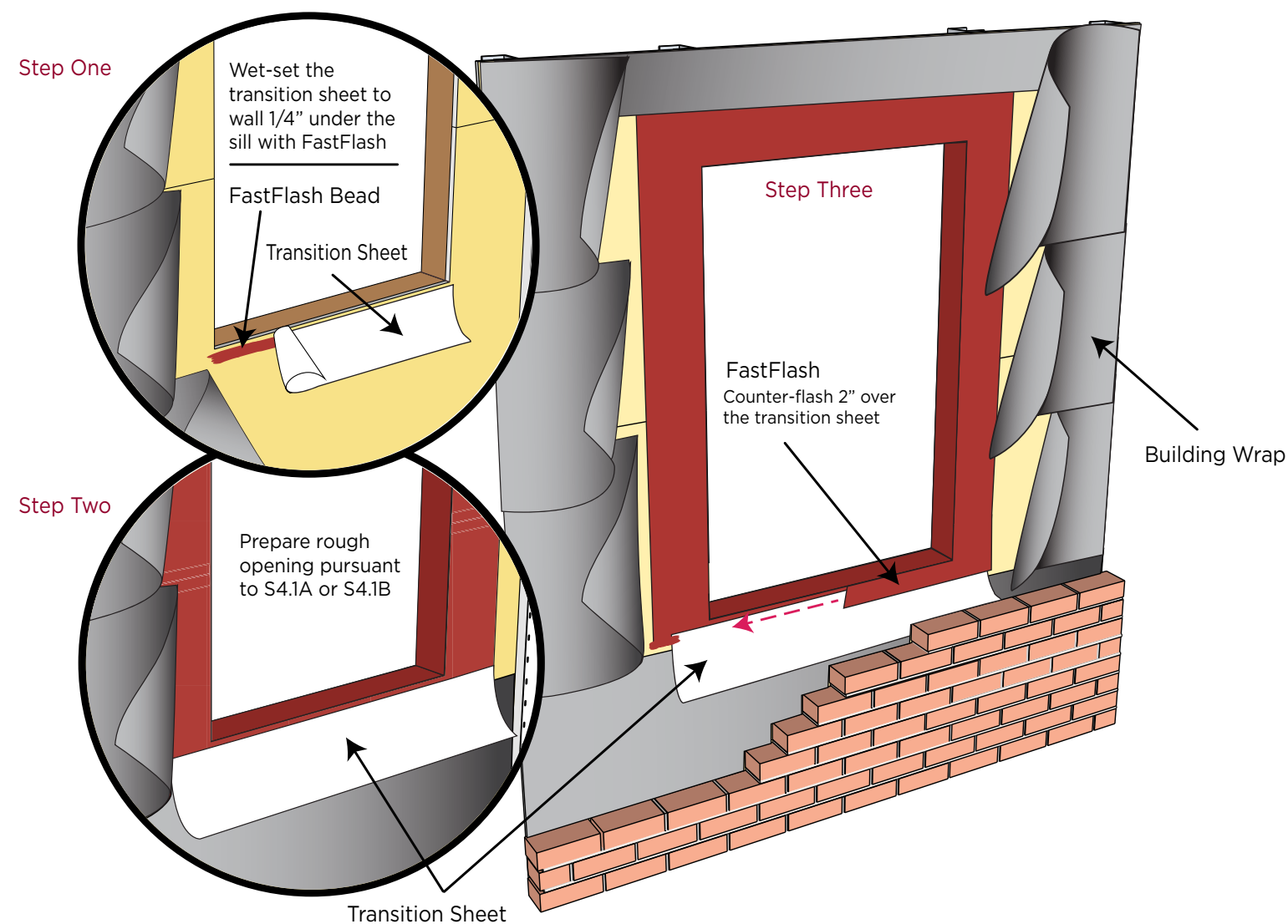

R-Guard

Deflection Joint 1 Inch and Smaller - S12.1A

AIR & WATER BARRIERS

Sheathing Wall Construction with gypsum, plywood or OSB sheathing.

Limit the size of the deflection joint to no more than 1 inch in width. If larger sizes of deflection joint occur, please contact manufacturer for additional detail information.

Apply **PorousPrep** over raw edge of sheathing board.

Install non-gassing polyethylene foam backer rod into joint opening in preparation to receive **Joint & Seam Filler**.

Apply **Joint & Seam Filler** into opening, over-filling the joint to provide enough material to tool excess on both sides of the joint, about 1 inch on either side.

After **Joint & Seam Filler** has skinned over, apply a 4-inch-wide application of **FastFlash** banding over the **Joint & Seam Filler** in a bridge-joint configuration.

After **FastFlash** has skinned over, apply **Cat 5** or another water- and air-resistive barrier over entire joint.

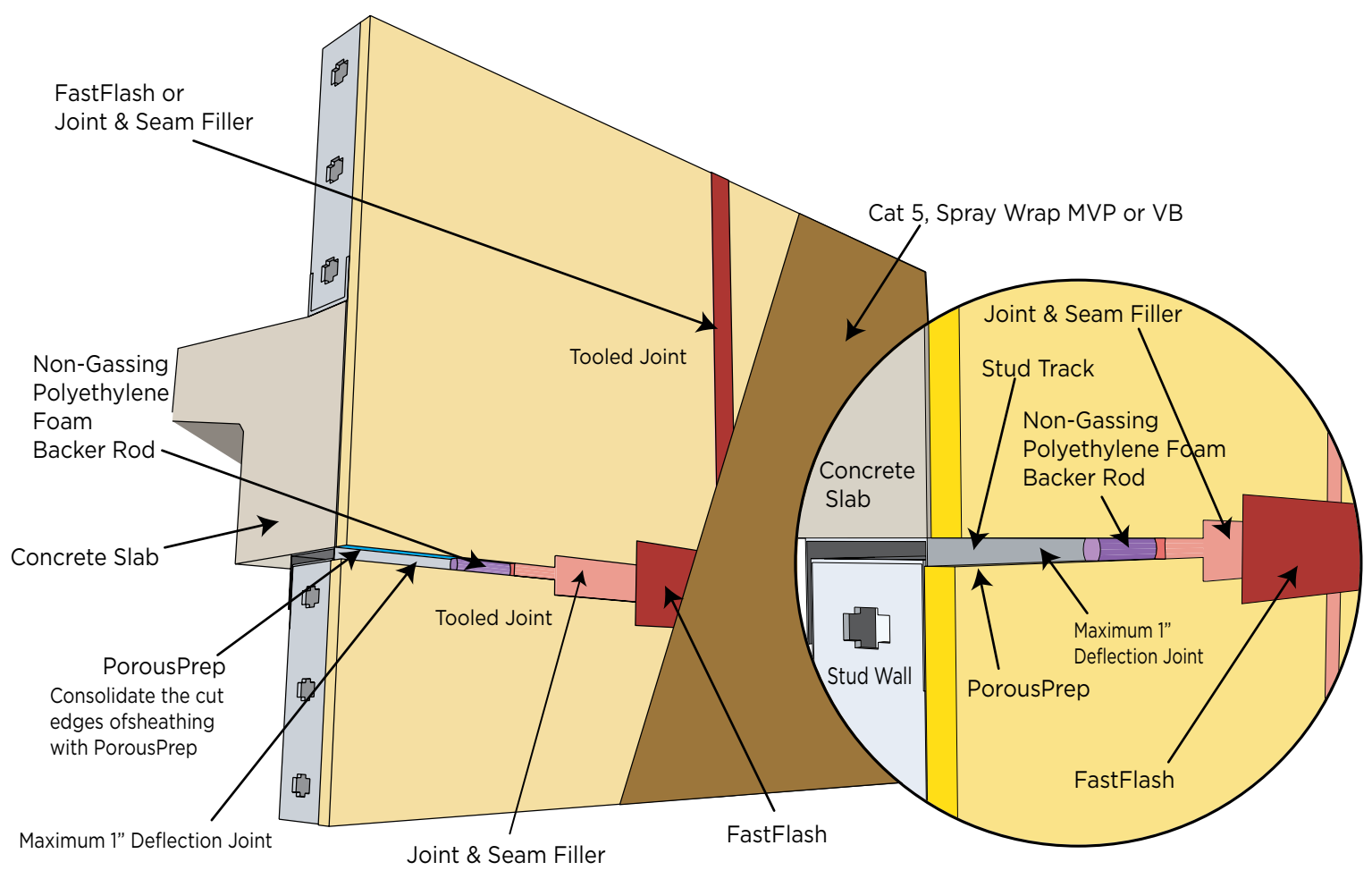

R-Guard

Deflection Joint Greater than 1 Inch - S12.1B

AIR & WATER BARRIERS

Sheathing Wall Construction with gypsum, plywood or OSB sheathing.

Apply **SureSpan Adhesive** to both sides of the joint. A 3/8-inch bead on both sides of the joint will spread to a width of 1/2 inch (12-15 mils thick). Sealant coverage may vary depending on the porosity or texture of substrate. Place the **SureSpan EX** into the wet sealant using hand pressure to adequately spread the **SureSpan Adhesive** onto the extrusion, usually squeezing a small amount of **SureSpan Adhesive** out alongside the extrusion. Small adjustments to the placement of the **SureSpan EX** may be done at this time, but lifting and re-seating should be avoided and may result in needing

additional **SureSpan Adhesive** installed to fully engage the extrusion into the wet sealant. Use a small roller such as a laminate roller to apply sufficient pressure to set the **SureSpan Adhesive**. Prior to tooling the excess **SureSpan Adhesive** alongside the extrusion, shoot an additional 1/4-inch bead of **SureSpan Adhesive** to smooth out and counterflash the exposed edge of the extrusion 3/4 of an inch. Tool excessive sealant immediately.

Masking tape, if used, must be removed before the **SureSpan Adhesive** begins to form a skin.

Surfaces must be clean of any type of contamination which impair adhesion of the FastFlash to the structural substrate. Cleaning must be done on the same day on which the FastFlash is applied. Place non-gassing polyethylene foam backer rod into joint opening. This will support and protect the SureSpan EX as it is working in movement conditions (i.e. expansion/contraction/shear).

Horizontal Joint Condition

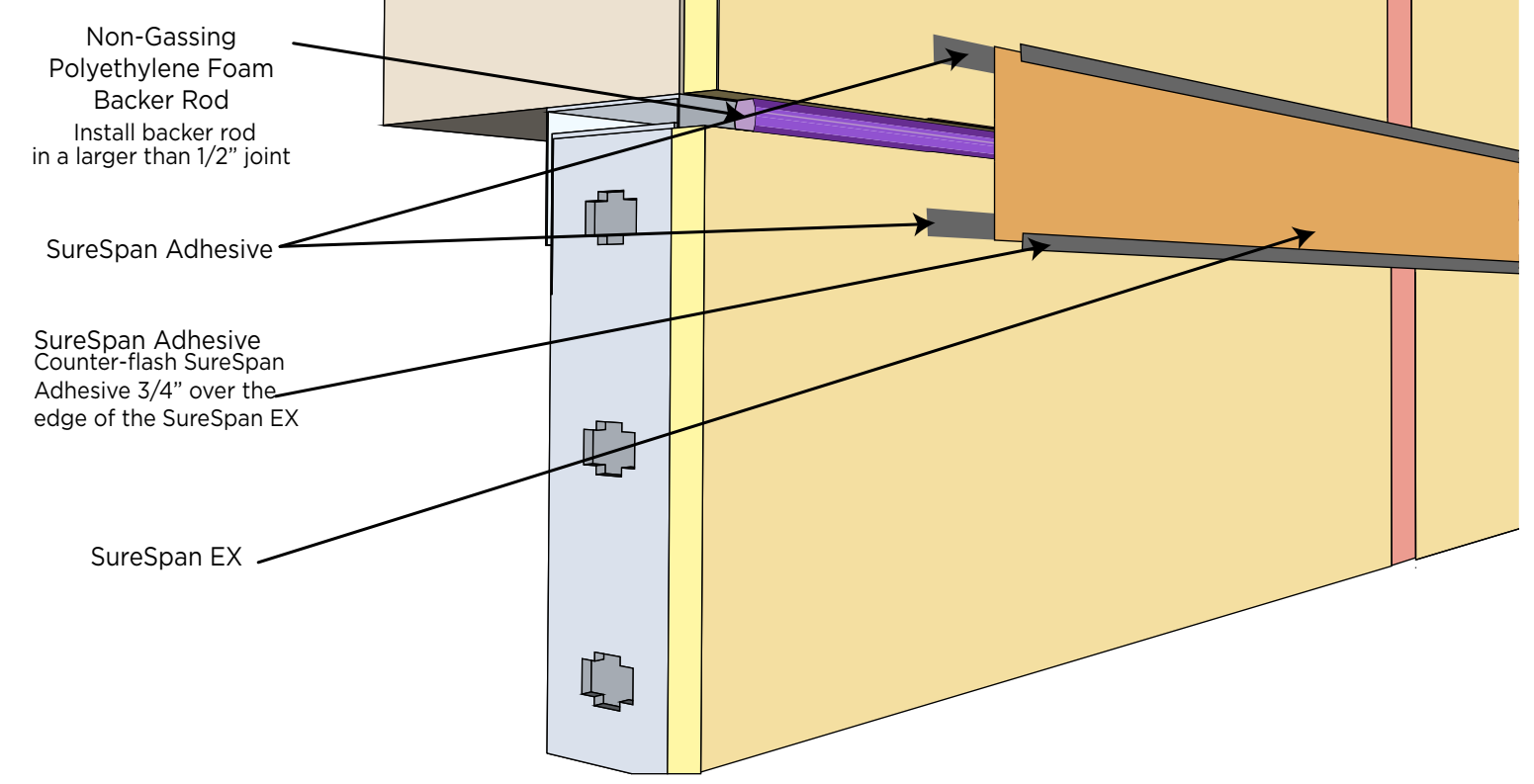

R-Guard

Deflection Joint Corner Condition Greater than 1" - S12.1C

AIR & WATER BARRIERS

Sheathing Wall Construction with gypsum, plywood or OSB sheathing.

Apply **SureSpan Adhesive** to both sides of the joint. A 3/8-inch bead on both sides of the joint will spread to a width of 1/2 inch (12-15 mils thick). Sealant coverage may vary depending on the porosity or texture of substrate. Place the **SureSpan EX** into the wet sealant using hand pressure to adequately spread the **SureSpan Adhesive** onto the extrusion, usually squeezing a small amount of **SureSpan Adhesive** out alongside the extrusion. Small adjustments to the placement of the **SureSpan EX** may be done at this time, but lifting and re-seating should be avoided and may result in needing additional **SureSpan Adhesive** installed to fully engage the extrusion into the wet sealant. Use a small roller such as a laminate roller to apply sufficient pressure to set the **SureSpan Adhesive**.

Horizontal joints must be completed before application of vertical joints. Vertical joints should be lapped over the horizontal joint as shown below. If mitered or field-cut corners are used, apply enough sealant under the corner joint so the excess sealant fills the miter joint.

Prior to tooling the excess **SureSpan Adhesive** alongside the extrusion, shoot an additional 1/4-inch bead of **SureSpan Adhesive** to smooth out and counterflash the exposed edge of the extrusion 3/4 of an inch. Tool excessive sealant immediately.

Masking tape, if used, must be removed before the **SureSpan Adhesive** begins to form a skin.

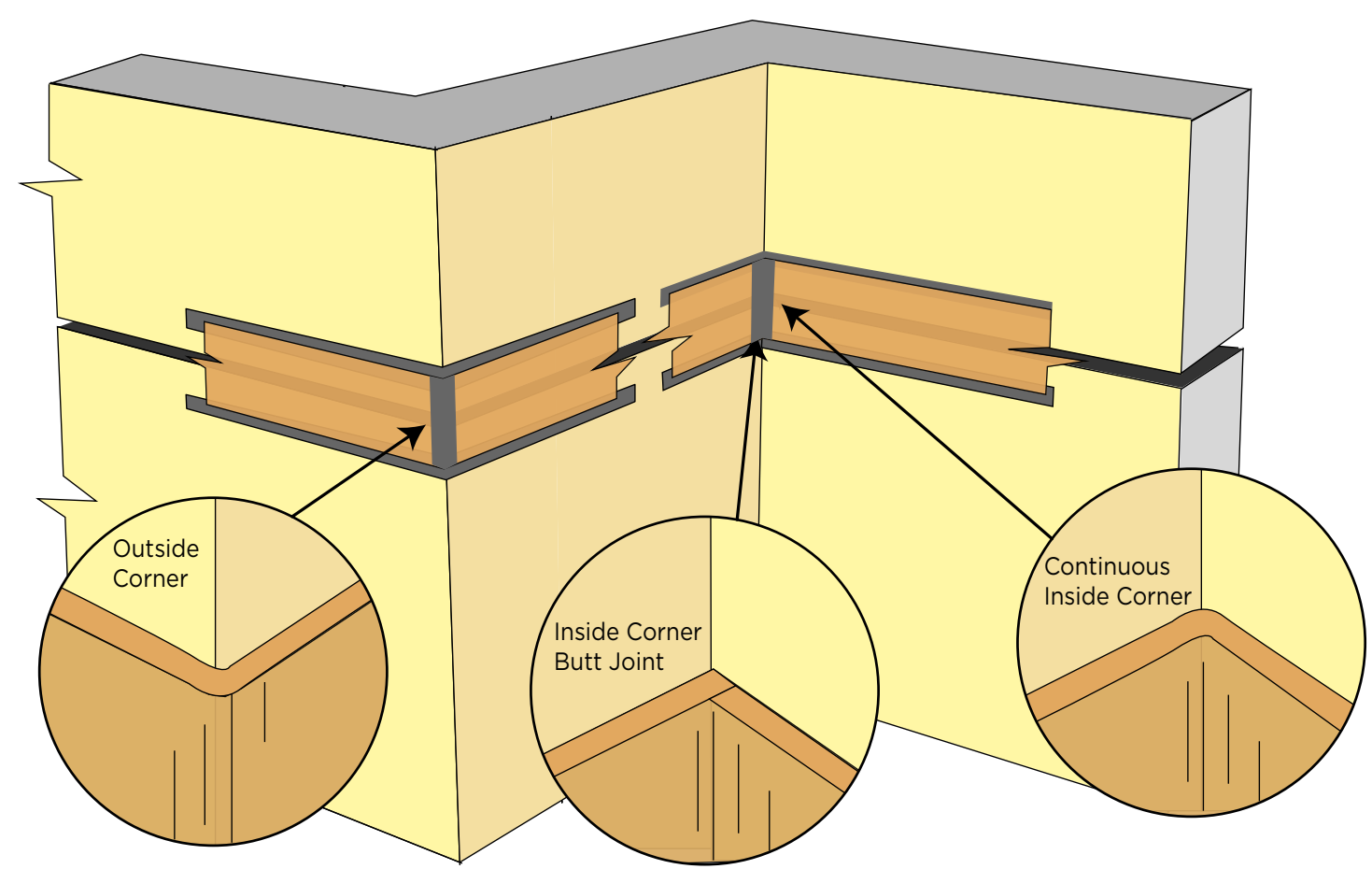

R-Guard

Rough Opening with FastFlash & Building Wrap S13.1

AIR & WATER BARRIERS

Sheathing Wall Construction with gypsum, plywood or OSB sheathing.

Begin with **FastFlash** applied as in S4.1A or **FastFlash** and **Joint & Seam Filler** applied as in S4.1B.

Step One Apply **AirDam** to the outer edge of the rough opening and tool to 20-25 wet mils.

Step Two Press building wrap into wet **AirDam**.

Step Three Apply **AirDam** at interface of building wrap and rough opening, and tool it to 20-25 mils, so that it half covers the building wrap and half overlaps into the rough opening.

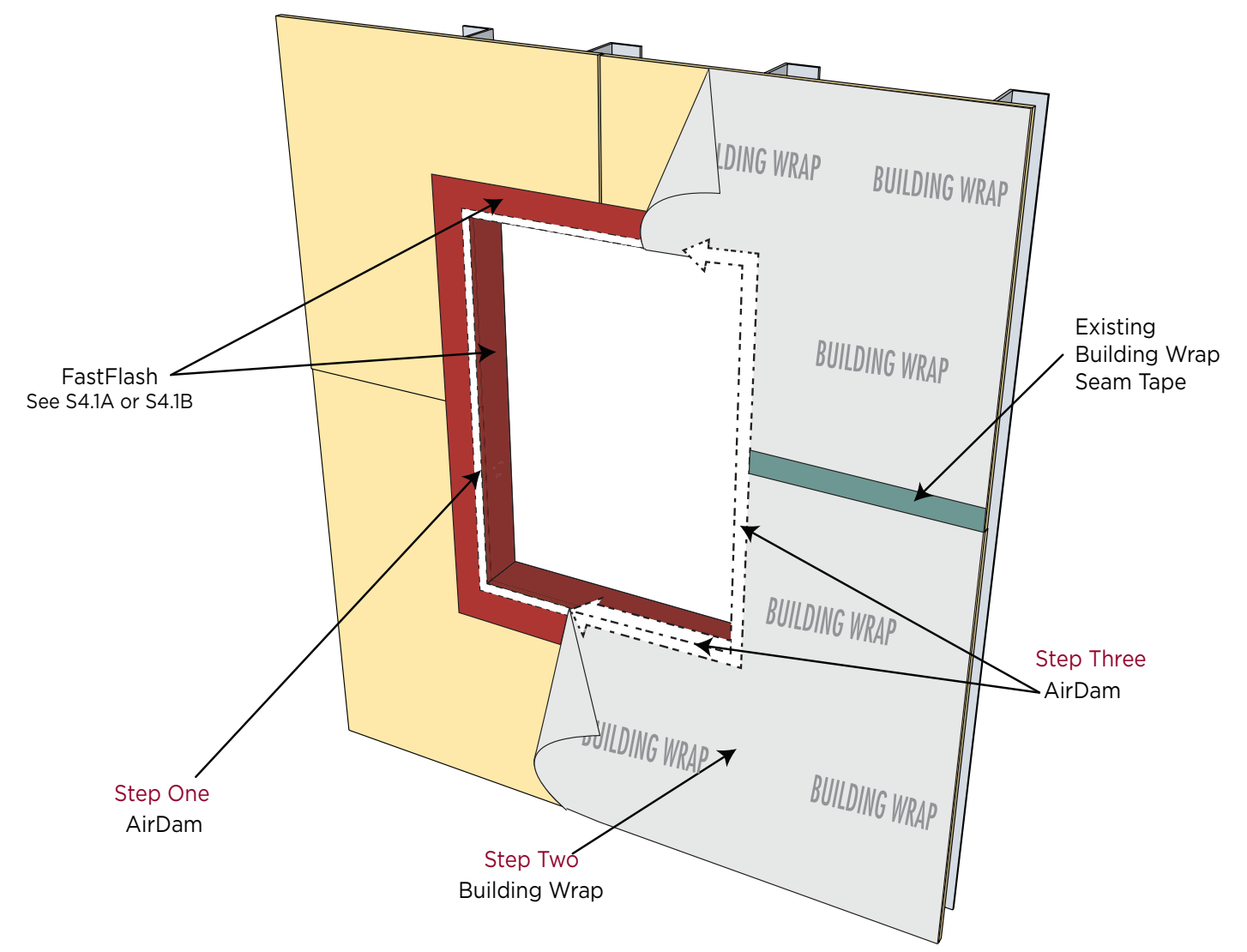

Vertical Expansion Joint - S14.1

Sheathing Wall Construction with gypsum, plywood or OSB sheathing.

Apply **SureSpan Adhesive** to both sides of the joint. A 3/8-inch bead on both sides of the joint will spread to a width of 1/2 inch (12-15 mils thick). Sealant coverage may vary depending on the porosity or texture of substrate. Place the **SureSpan EX** into the wet sealant using hand pressure to adequately spread the **SureSpan Adhesive** onto the extrusion, usually squeezing a small amount of **SureSpan Adhesive** out alongside the extrusion. Small adjustments to the placement of the **SureSpan EX** may be done at this time, but lifting and re-seating should be avoided and may result in needing additional **SureSpan Adhesive** installed to fully engage the extrusion

into the wet sealant. Use a small roller such as a laminate roller to apply sufficient pressure to set the **SureSpan Adhesive**. Prior to tooling the excess **SureSpan Adhesive** alongside the extrusion, shoot an additional 1/4-inch bead of **SureSpan Adhesive** to smooth out and counterflash the exposed edge of the extrusion 3/4 of an inch. Tool excessive sealant immediately.

Masking tape, if used, must be removed before the **SureSpan Adhesive** begins to form a skin.

Vertical Expansion Joint Condition

Surfaces must be clean of any type of contamination which impair adhesion of the SureSpan Adhesive to the structural substrate. Cleaning must be done on the same day on which the SureSpan Adhesive is applied. Place non-gassing polyethylene foam backer rod into joint opening. This will support and protect the SureSpan EX as it is working in movement conditions (i.e. expansion/contraction/shear).

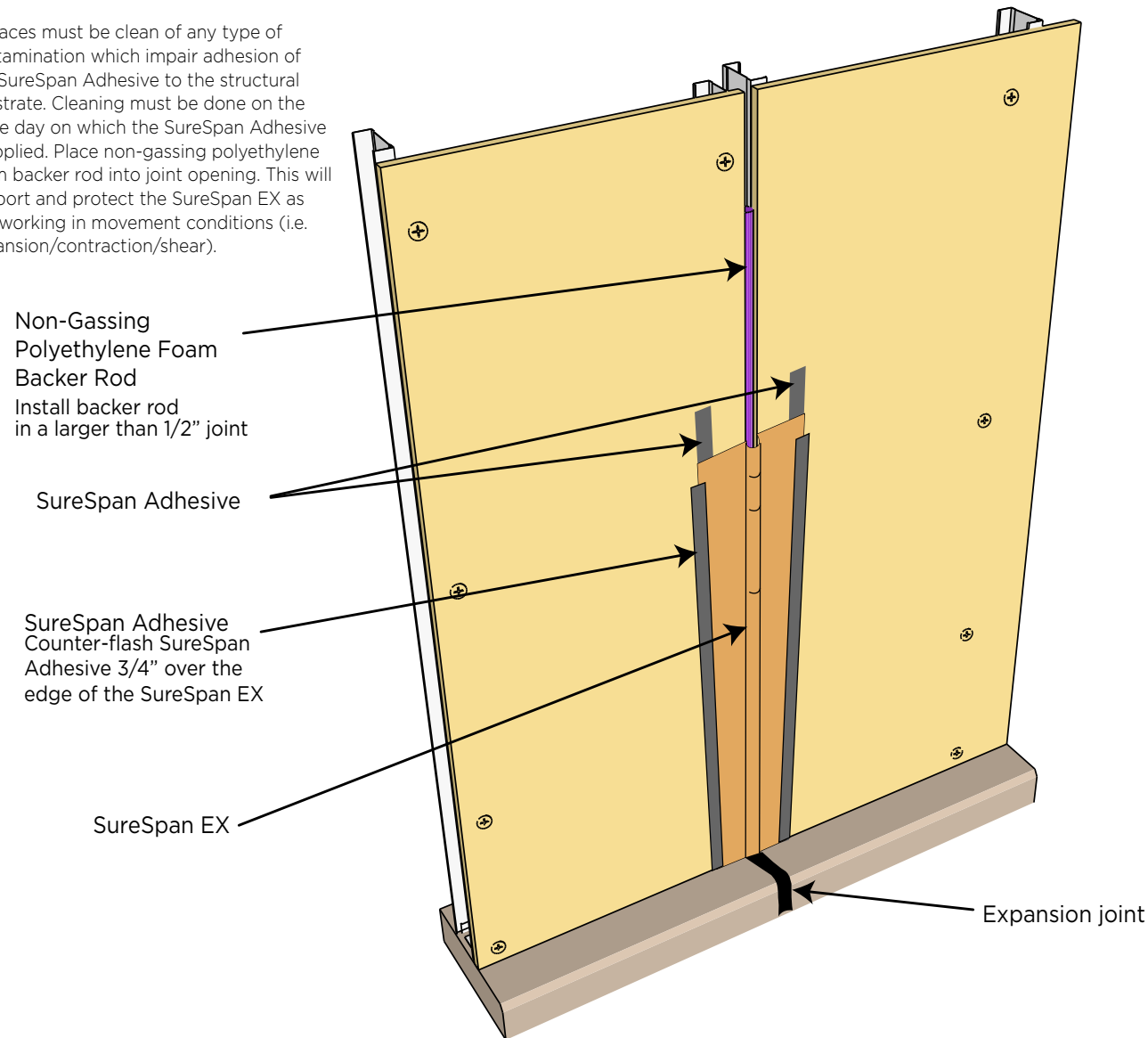

Vertical Expansion at Dissimilar Substrate > 1"-Wide - S14.2

Sheathing Wall Construction with gypsum, plywood or OSB sheathing.

Apply **SureSpan Adhesive** to both sides of the joint. A 3/8-inch bead on both sides of the joint will spread to a width of 1/2 inch (12-15 mils thick). Sealant coverage may vary depending on the porosity or texture of substrate. Place the **SureSpan EX** into the wet sealant using hand pressure to adequately spread the **SureSpan Adhesive** onto the extrusion, usually squeezing a small amount of **SureSpan Adhesive** out alongside the extrusion. Small adjustments to the placement of the **SureSpan EX** may be done at this time, but lifting and re-seating should be avoided and may result in needing additional

SureSpan Adhesive installed to fully engage the extrusion into the wet sealant. Use a small roller such as a laminate roller to apply sufficient pressure to set the **SureSpan Adhesive**. Prior to tooling the excess **SureSpan Adhesive** alongside the extrusion, shoot an additional 1/4-inch bead of **SureSpan Adhesive** to smooth out and counterflash the exposed edge of the extrusion 3/4 of an inch. Tool excessive sealant immediately.

Masking tape, if used, must be removed before the **SureSpan Adhesive** begins to form a skin.

Vertical Expansion Joint at Dissimilar Substrate Interface

Surfaces must be clean of any type of contamination which impair adhesion of the SureSpan Adhesive to the structural substrate. Cleaning must be done on the same day on which the SureSpan Adhesive is applied. Place non-gassing polyethylene foam backer rod into joint opening. This will support and protect the SureSpan EX as it is working in movement conditions (i.e. expansion/contraction/shear).

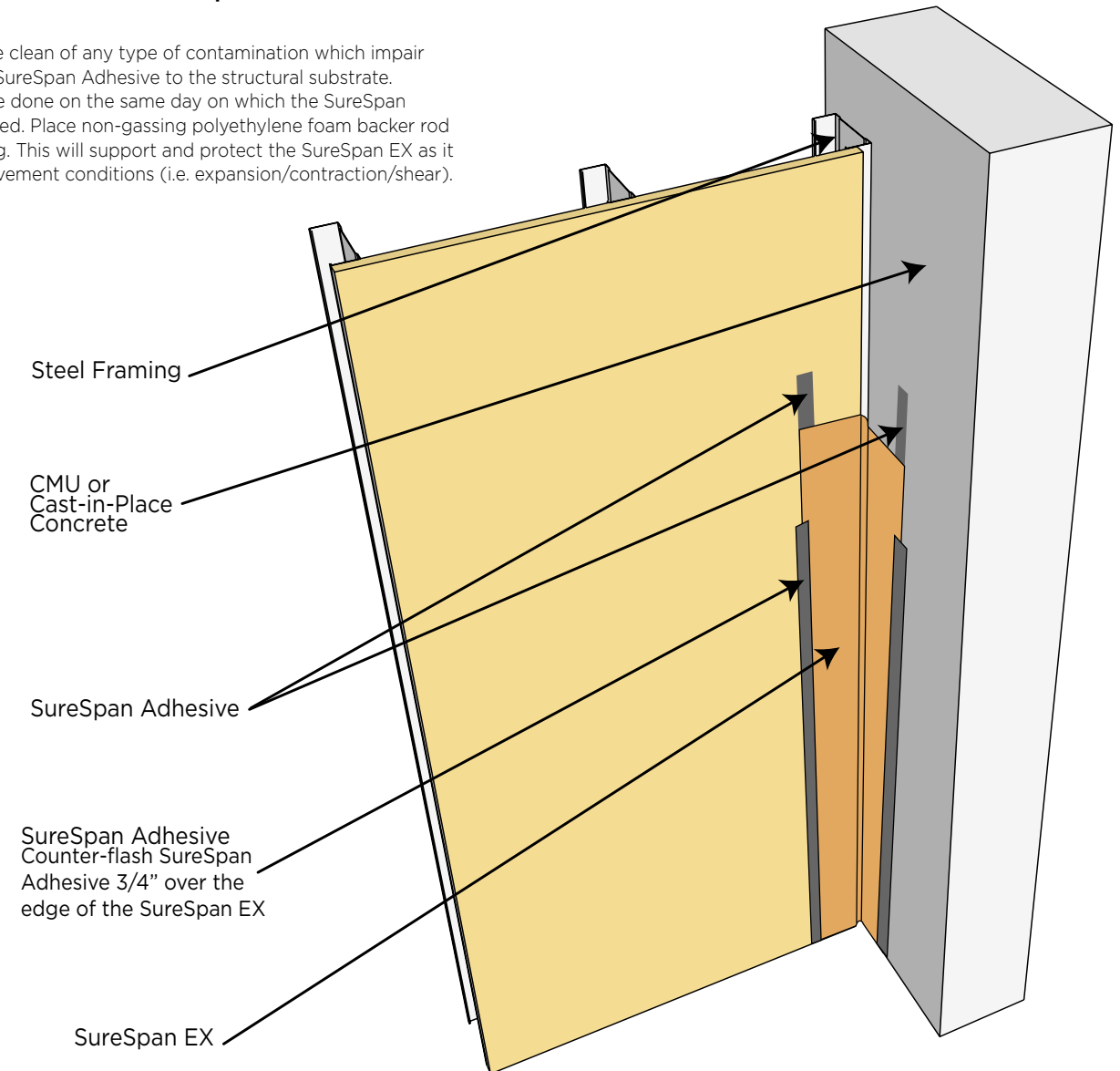

R-Guard®

Overlap/Splice Joint of SureSpan EX - S14.3

AIR & WATER BARRIERS

Sheathing Wall Construction with gypsum, plywood or OSB sheathing.

Apply **SureSpan Adhesive** to both sides of the joint. A 3/8-inch bead on both sides of the joint will spread to a width of 1/2 inch (12-15 mils thick). Sealant coverage may vary depending on the porosity or texture of substrate. Place the **SureSpan EX** into the wet sealant using hand pressure to adequately spread the **SureSpan Adhesive** onto the extrusion, usually squeezing a small amount of **SureSpan Adhesive** out alongside the extrusion. Small adjustments to the placement of the **SureSpan EX** may be done at this time, but lifting and re-seating should be avoided and may result in needing additional **SureSpan Adhesive** installed to fully engage the extrusion into the wet sealant. Use a small roller such as a laminate

roller to apply sufficient pressure to set the **SureSpan Adhesive**. **Vertical joints should be overlapped as shown below. If mitered or field-cut corners are used, apply enough sealant under the corner joint so the excess sealant fills the miter joint.**

Prior to tooling the excess **SureSpan Adhesive** alongside the extrusion, shoot an additional 1/4-inch bead of **SureSpan Adhesive** to smooth out and counterflash the exposed edge of the extrusion 3/4 of an inch. Tool excessive sealant immediately.

Masking tape, if used, must be removed before the **SureSpan Adhesive** begins to form a skin.

R-Guard®

Corner Overlap/Butt Joint of SureSpan EX - S14.4

AIR & WATER BARRIERS

Sheathing Wall Construction with gypsum, plywood or OSB sheathing.

Apply **SureSpan Adhesive** to both sides of the joint. A 3/8-inch bead on both sides of the joint will spread to a width of 1/2 inch (12-15 mils thick). Sealant coverage may vary depending on the porosity or texture of substrate. Place the **SureSpan EX** into the wet sealant using hand pressure to adequately spread the **SureSpan Adhesive** onto the extrusion, usually squeezing a small amount of **SureSpan Adhesive** out alongside the extrusion. Small adjustments to the placement of the **SureSpan EX** may be done at this time, but lifting and re-seating should be avoided and may result in needing additional **SureSpan Adhesive** installed to fully engage the extrusion into the wet sealant. Use a small roller such as a laminate roller to apply sufficient pressure to set the **SureSpan Adhesive**.

Horizontal joints must be completed before application of vertical joints. Vertical joints should be lapped over the horizontal joints as shown below. If mitered or field-cut corners are used, apply enough sealant under the corner joint so the excess sealant fills the miter joint.

Prior to tooling the excess **SureSpan Adhesive** alongside the extrusion, shoot an additional 1/4-inch bead of **SureSpan Adhesive** to smooth out and counterflash the exposed edge of the extrusion 3/4 of an inch. Tool excessive sealant immediately.

Masking tape, if used, must be removed before the **SureSpan Adhesive** begins to form a skin.

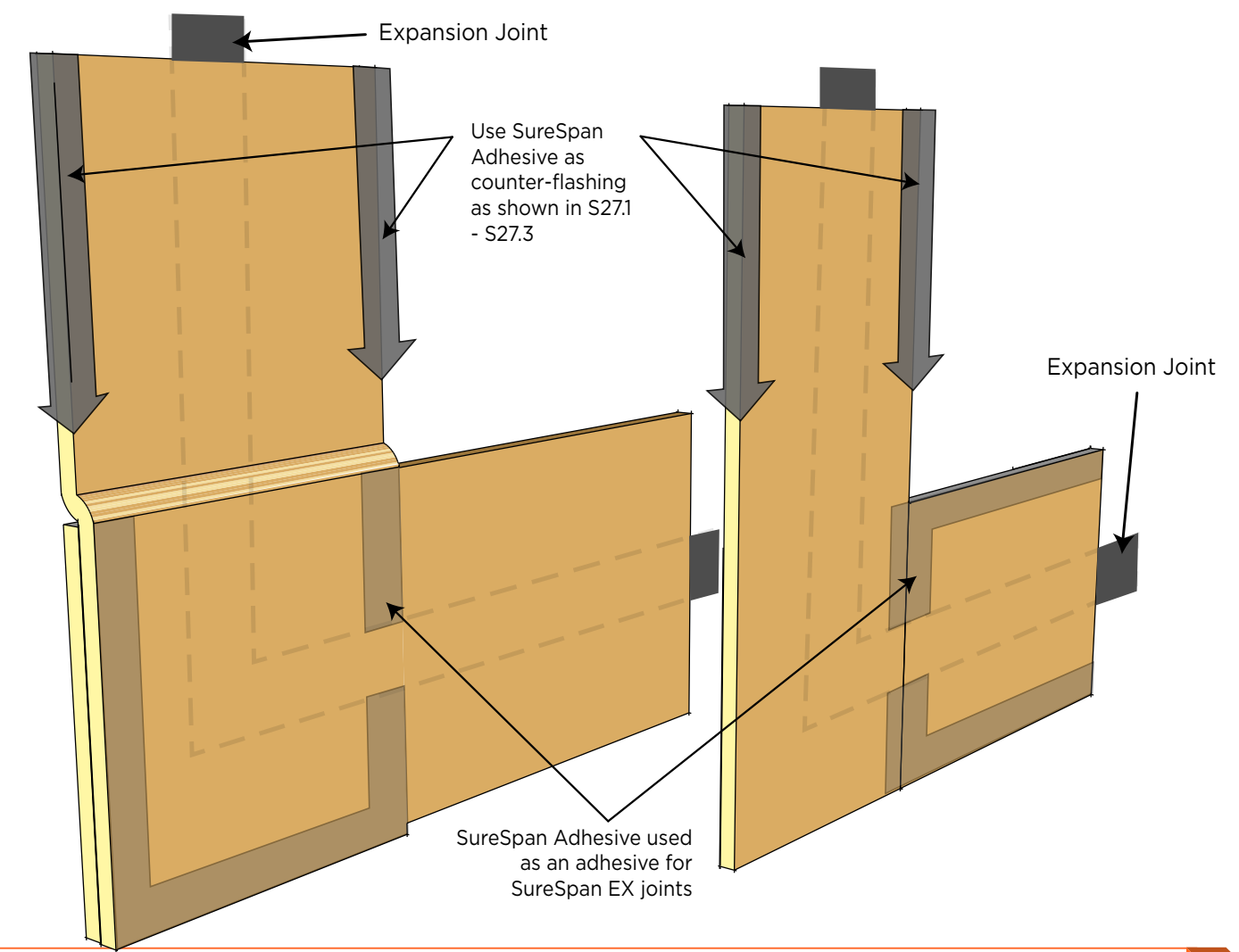
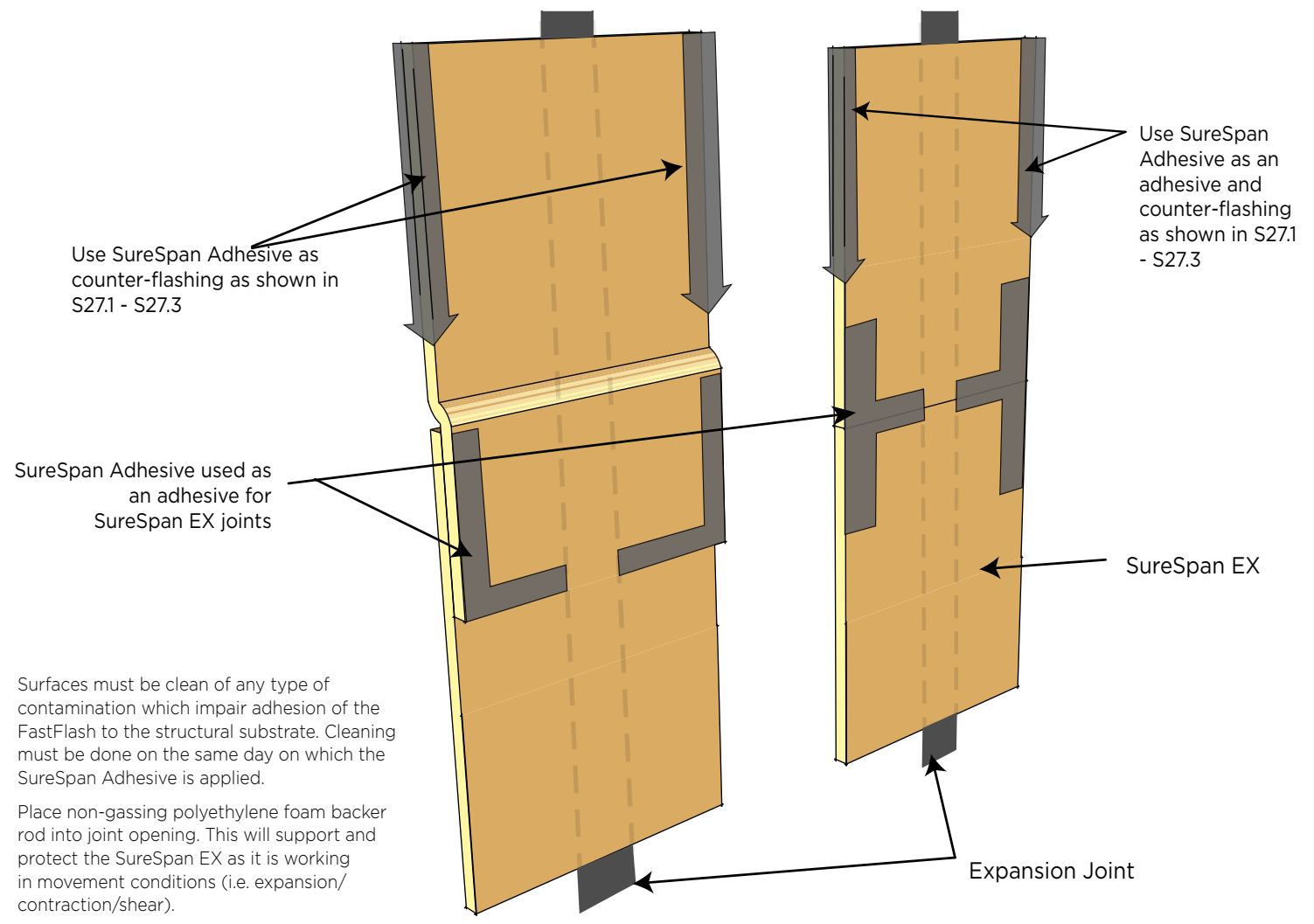

R-Guard

Joint Intersection SureSpan EX - S14.5

AIR & WATER BARRIERS

Sheathing Wall Construction with gypsum, plywood or OSB sheathing.

Apply **SureSpan Adhesive** to both sides of the joint. A 3/8-inch bead on both sides of the joint will spread to a width of 1/2 inch (12-15 mils thick). Sealant coverage may vary depending on the porosity or texture of substrate. Place the **SureSpan EX** into the wet sealant using hand pressure to adequately spread the **SureSpan Adhesive** onto the extrusion, usually squeezing a small amount of **SureSpan Adhesive** out alongside the extrusion. Small adjustments to the placement of the **SureSpan EX** may be done at this time, but lifting and re-seating should be avoided and may result in needing additional **SureSpan Adhesive** installed to fully engage the extrusion into the wet sealant. Use a small roller such as a laminate roller to apply sufficient pressure to set the **SureSpan**

Adhesive. Horizontal joints must be completed before application of vertical joints. Vertical joints should be lapped over the horizontal joints as shown below. If mitered or field-cut corners are used, apply enough sealant under the corner joint so the excess sealant fills the miter joint.

Prior to tooling the excess **SureSpan Adhesive** alongside the extrusion, shoot an additional 1/4-inch bead of **SureSpan Adhesive** to smooth out and counterflash the exposed edge of the extrusion 3/4 of an inch. Tool excessive sealant immediately.

Masking tape, if used, must be removed before the **SureSpan Adhesive** begins to form a skin.

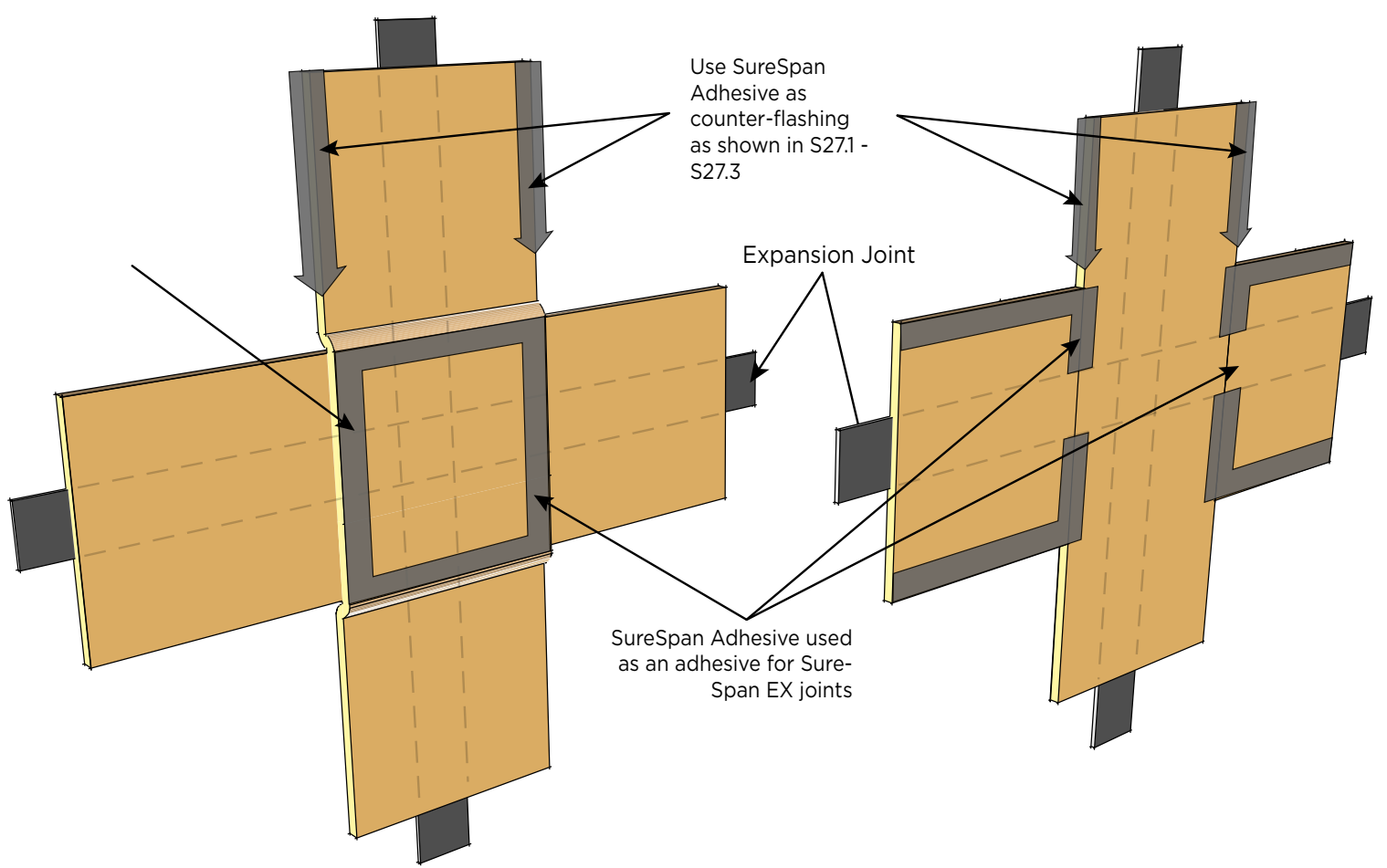

R-Guard

CMU/CIP Concrete Rough Opening - C1.1

AIR & WATER BARRIERS

CMU/Cast-in-Place Concrete Wall Construction

Field of wall – Fill small voids and cracks (up to 1/2-inch) in the CMU surface with **FastFlash** or **Joint & Seam Filler**. Use a dry joint knife or trowel to press and spread 1 inch beyond each side to a thickness of 20-30 mils.

Repair larger cracks or voids with mortar.

Best practice rough opening – Apply a thick bead of **FastFlash** in each corner and in a zigzag pattern over the concrete block inside the rough opening and wall face surrounding the rough opening. Use a dry joint knife, trowel or chipper brush to spread the wet product to protect the rough opening with a seamless flashing membrane that extends no more than 1 inch over the face of the wall. Apply additional **FastFlash** as needed to create an opaque, monolithic flashing membrane free of voids or pinholes. Allow to skin over.

Spray or roller apply the selected R-Guard air and water-resistive barrier over the prepared wall. Apply sufficient product to cover the entire face of the structural wall.

Wood buck -- If wood bucks are not already installed, apply two thick beads of **FastFlash** or **Joint & Seam Filler** along the perimeter faces of the wood buck before attaching it to the structure while still wet. Install anchor bolts.

After installation of wood buck, spot and cover the installed heads of the anchor bolts. Apply a thick bead of **FastFlash** or **Joint & Seam Filler** to all inside corners of the wood buck. Use a dry joint knife or trowel to press and spread 1 inch beyond each side to a thickness of 20-30 mils.

Apply a thick bead of **FastFlash** or **Joint & Seam Filler** to the perimeter joint between the wood buck and the CMU wall. Use a dry trowel or spatula to tool and seal the joint. Create a profile that directs bulk water away from the joint. Allow **Joint & Seam Filler** to skin over.

Apply a thick bead of **FastFlash** over the inside of the wood buck, extending it onto the wall surrounding the rough opening. Use a dry joint knife, chip brush or trowel to spread the wet product to create a seamless flashing membrane. To ensure the wood buck is adequately protected, make sure the membrane extends no more than 1 inch over the face of the wall. Apply additional **FastFlash** as needed to create an opaque, monolithic flashing membrane free of voids or pinholes.

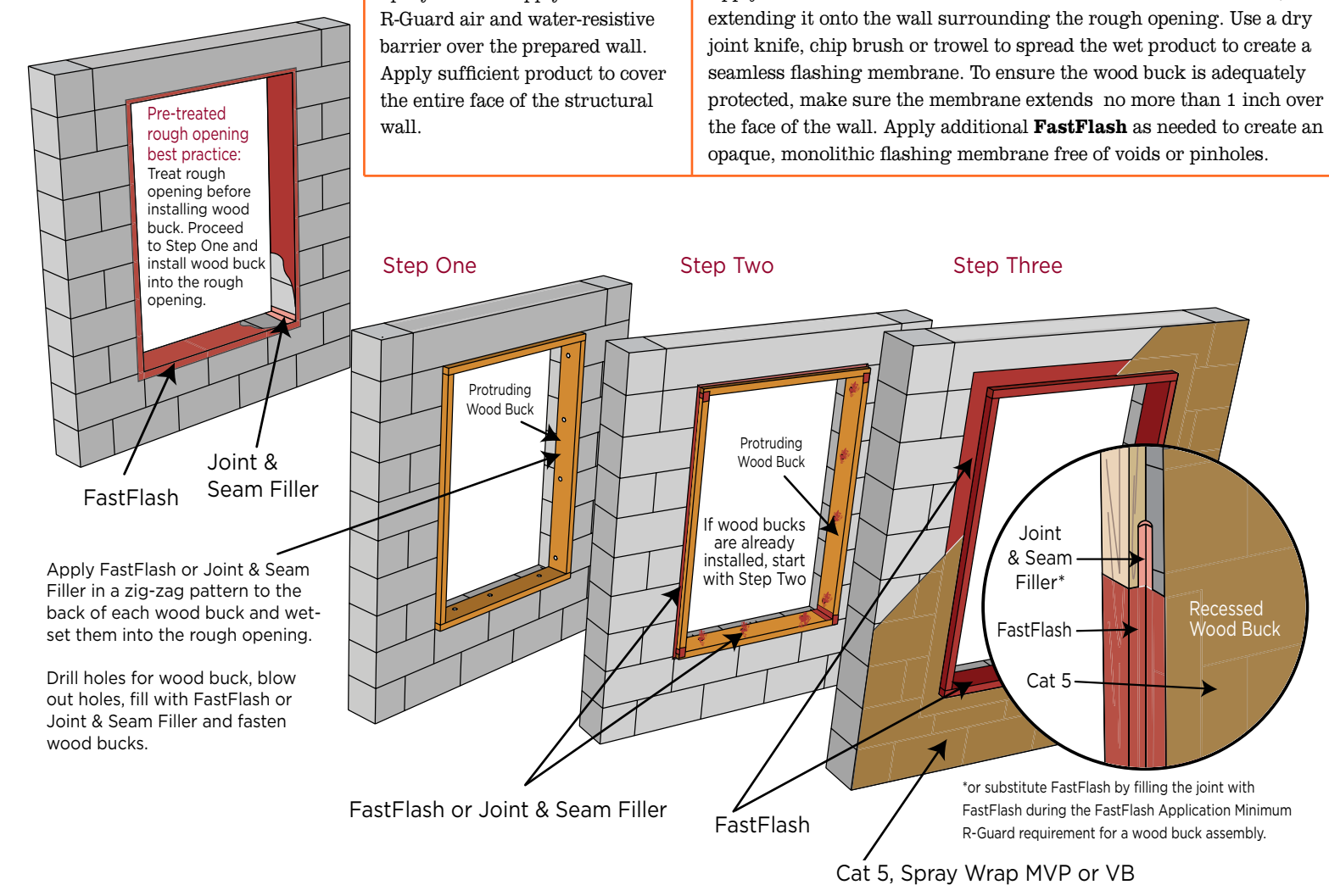

R-Guard

Pipe and Mechanical Penetrations - Concrete Block - C2.1

AIR & WATER BARRIERS

CMU/Cast-in-Place Concrete Wall Construction

Mechanically secure loose penetrations at the interior of the wall before detailing. Install non-gassing polyethylene foam backer rod backed by spray foam around electrical fixtures, conduit or plumbing to form a back dam.

Apply a thick bead of **FastFlash** or **Joint & Seam Filler** around the penetration. Use a dry trowel or spatula to tool and seal the joint. Create a joint profile that directs bulk water away from the penetration.

Apply the selected R-Guard air- and water-resistive barrier over the prepared wall. Use a brush to cover the **FastFlash** or **Joint & Seam Filler** that surrounds any mechanical penetrations. Apply sufficient product to cover the entire face of the structural wall and all exposed **FastFlash** or **Joint & Seam Filler**.

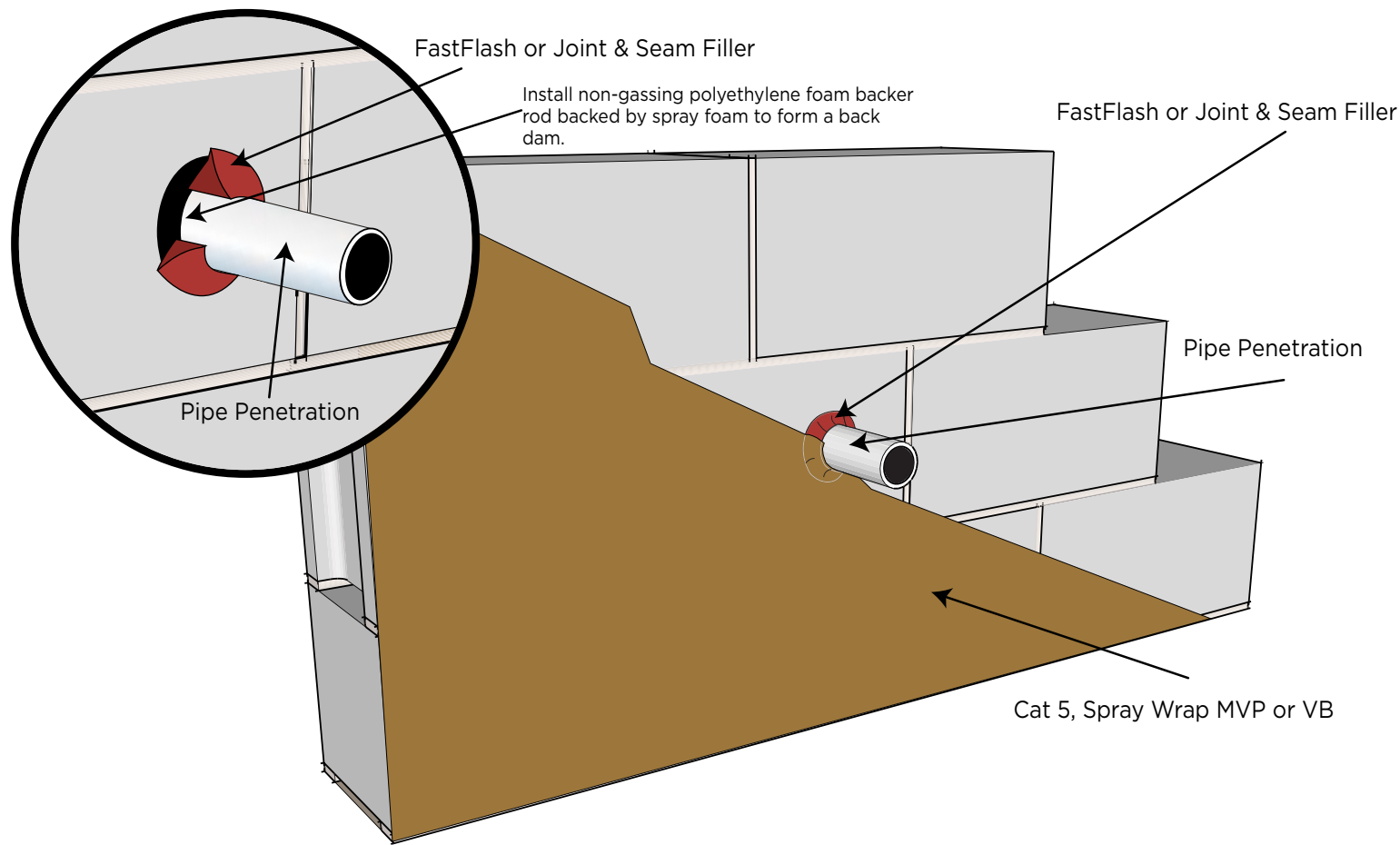

R-Guard

Roof-To-Wall Transition - Parapet to Roof Plane - C3.1

AIR & WATER BARRIERS

CMU/Cast-in-Place Concrete Wall Construction

Apply a thick bead of **FastFlash** or **Joint & Seam Filler** down the center of the structural member. Wet-set the wood blocking. Mechanically fasten the wood blocking. Spot the head of all fasteners that penetrate the wood blocking. Allow to skin over.

Apply a thick bead of **FastFlash** or **Joint & Seam Filler** to the joint between the wood blocking and the top of the wall. Use a dry trowel or spatula to tool and seal the joint. Create a profile that directs bulk water away from the joint. Allow to skin over.

To protect the parapet and to transition the air and water barrier to the roofing plane, apply and spread sufficient **FastFlash** to cover all exposed surfaces of the wood blocking.

Apply a thick bead of **FastFlash** in a zig-zag pattern immediately beneath the wood blocking on both faces of the parapet. Spread the wet product to create a seamless flashing membrane which covers the wood blocking and extends 4-6

inches down both faces of the parapet. **FastFlash** will overlap the air- and water-resistive barrier.

Apply additional **FastFlash** as needed to create an opaque, monolithic flashing membrane free of voids or pinholes.

Apply **FastFlash** or **Joint & Seam Filler** to inside parapet wall to fill all voids and failed mortar joints. If roof decking is used, fill all roof decking seams (see detail S1.1)

Apply a thick bead of **FastFlash** or **Joint & Seam Filler** to the base of the parapet wall and roof decking corner interface. Use a dry trowel or spatula to tool and seal the joint. Create a profile that directs bulk water away from the joint. Allow to skin over.

Roller apply **Cat 5** to the parapet sheathing wall and the roof decking to form a continuous membrane over the sheathing and roof decking.

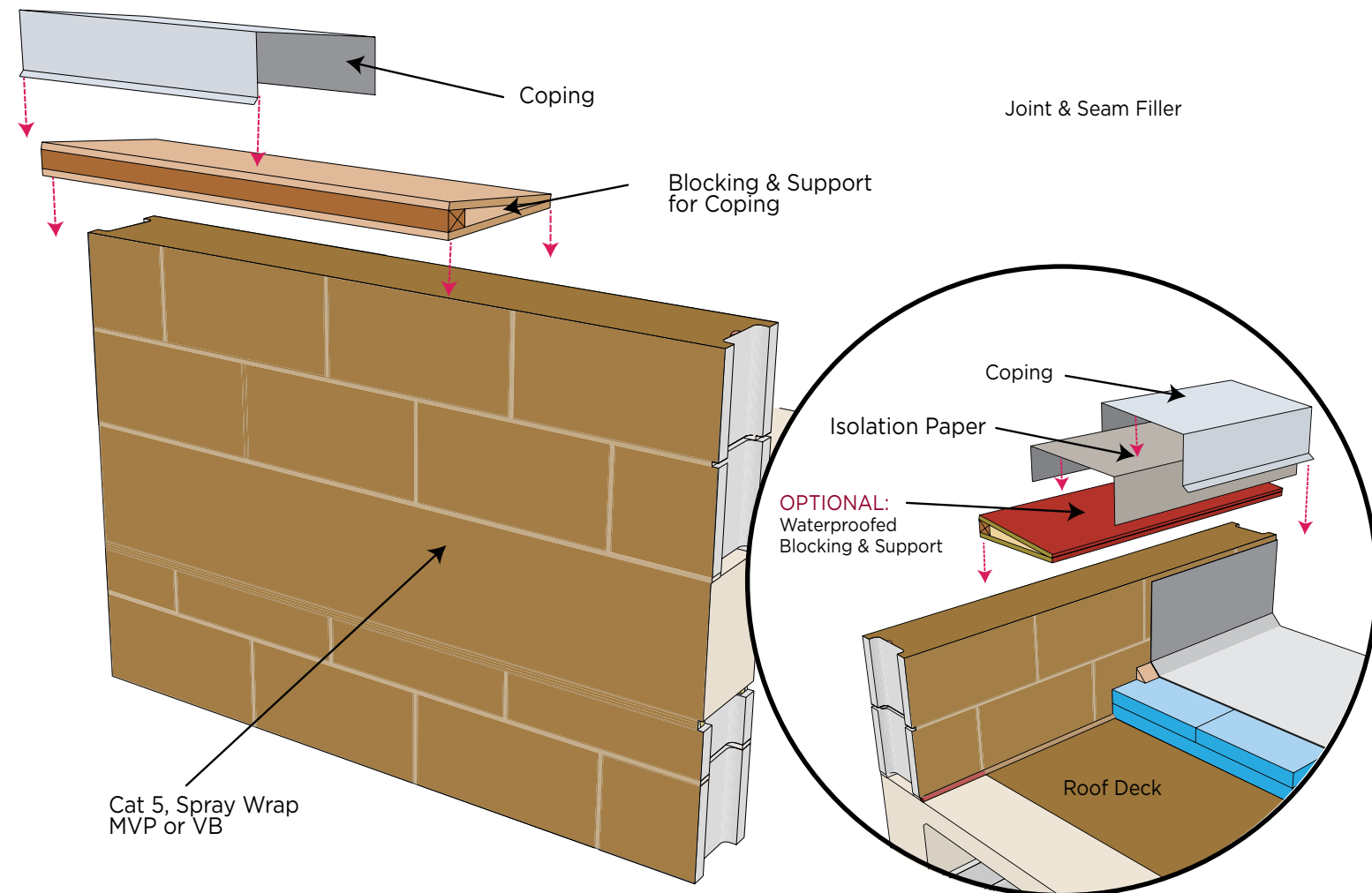

R-Guard®

CMU/CIP Concrete Arched Window Rough Opening - C4.1

AIR & WATER BARRIERS

CMU/Cast-in-Place Concrete Wall Construction

Arched wood framing and plywood sheathing is installed and detailed at inside 90 degree and corner splices with **FastFlash** or **Joint & Seam Filler** in preparation to receive **FastFlash** liquid-applied flashing membrane.

FastFlash covers the entire wood surface, terminating at the edge of the wood-to-CMU interface.

Radius windows are installed and placed into the opening, allowing the shims to be recessed to allow a backer rod and bead of **AirDam** to be continuously tooled around the inside perimeter of the window.

Fin/flange windows can be set in a bed of wet **FastFlash** at jamb/head/jamb locations, leaving the sill open. Shims beneath the flange should be set at quarter points of the window to allow for appropriate drainage.

An exterior weather bead of sealant can be installed, allowing for weep/drainage points to take place at the sill location(s).

Step 1

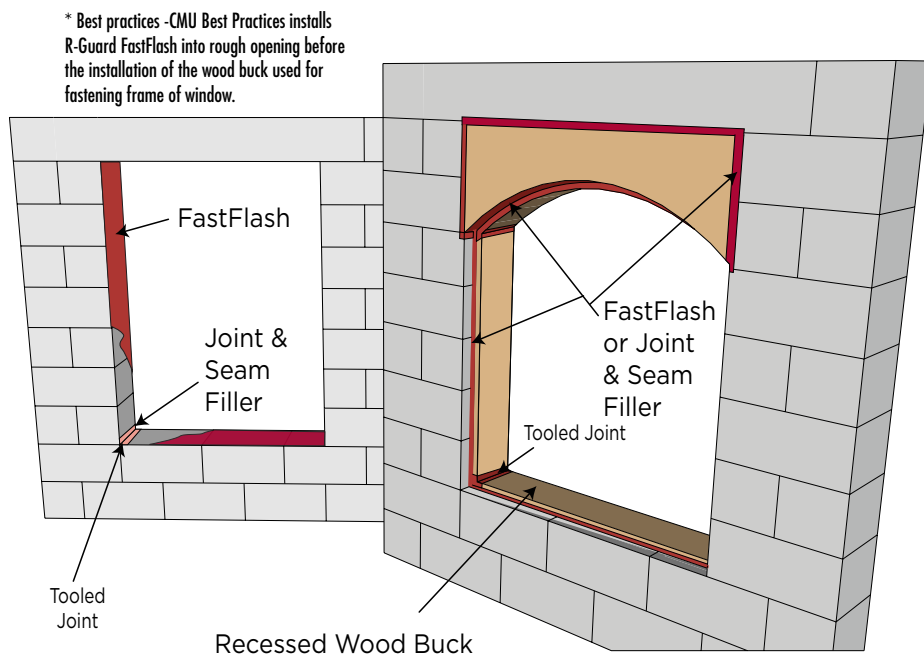

Step 2

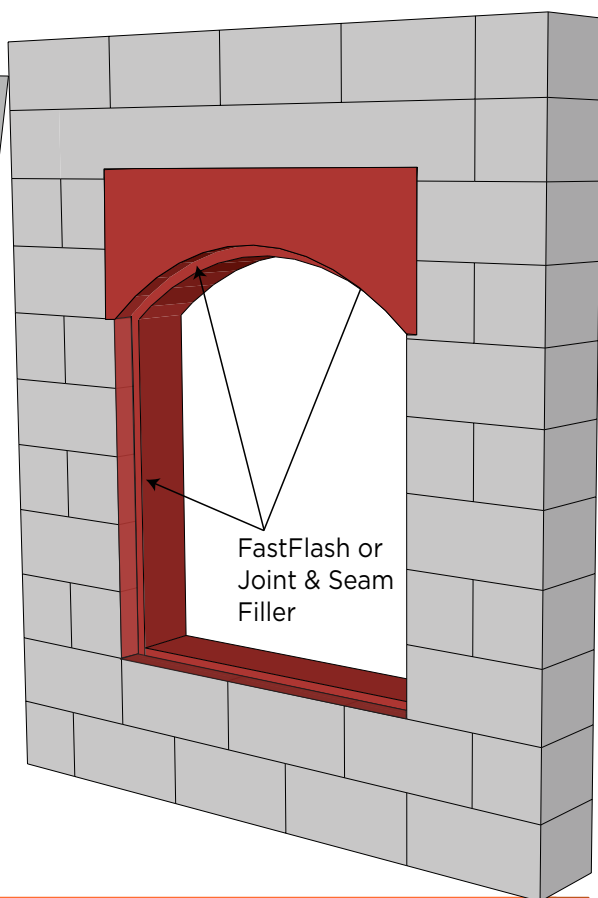

R-Guard®

Interior Air and Water Seal - C5.1

AIR & WATER BARRIERS

CMU/Cast-in-Place Concrete Wall Construction

Install the window "plumb, level and square" into the prepared rough opening.

Use **AirDam** as the interior air sealant to ensure compatibility with the treated rough opening and create a long-lasting, weather-tight seal. **AirDam** prevents bulk water and moist outside air from entering, and conditioned indoor air from escaping around the window. This ties the window into the larger air and water management system, and prevents water which may collect in the window frame from entering the conditioned space.

Joint Size - Sealant depth should be one-half the width of the joint. Maximum sealant depth should be 1/2 inch (13 mm). Minimum sealant depth should be 1/4 inch (6mm).

Minimum joint width should be 1/4 inch (6mm).

Joint Backing - A properly sized non-gassing polyethylene foam

backer rod should compress by 25-30% when installed. Install backer rod by compressing and rolling continuously into the joint channel without stretching or puncturing.

Where joint depth does not permit use of a backer rod, install a polyethylene strip or bond breaker tape over the bottom of the joint to prevent three-sided adhesion. Three-sided adhesion will restrict joint movement.

Installation - Install a continuous bead of **AirDam** without gaps or air pockets. Tool immediately with a dry spatula to ensure complete wetting of the joint bond surface and produce a smooth, concave joint profile.

FastFlash wraps into the rough opening in the structural wall. See detail C13.1.

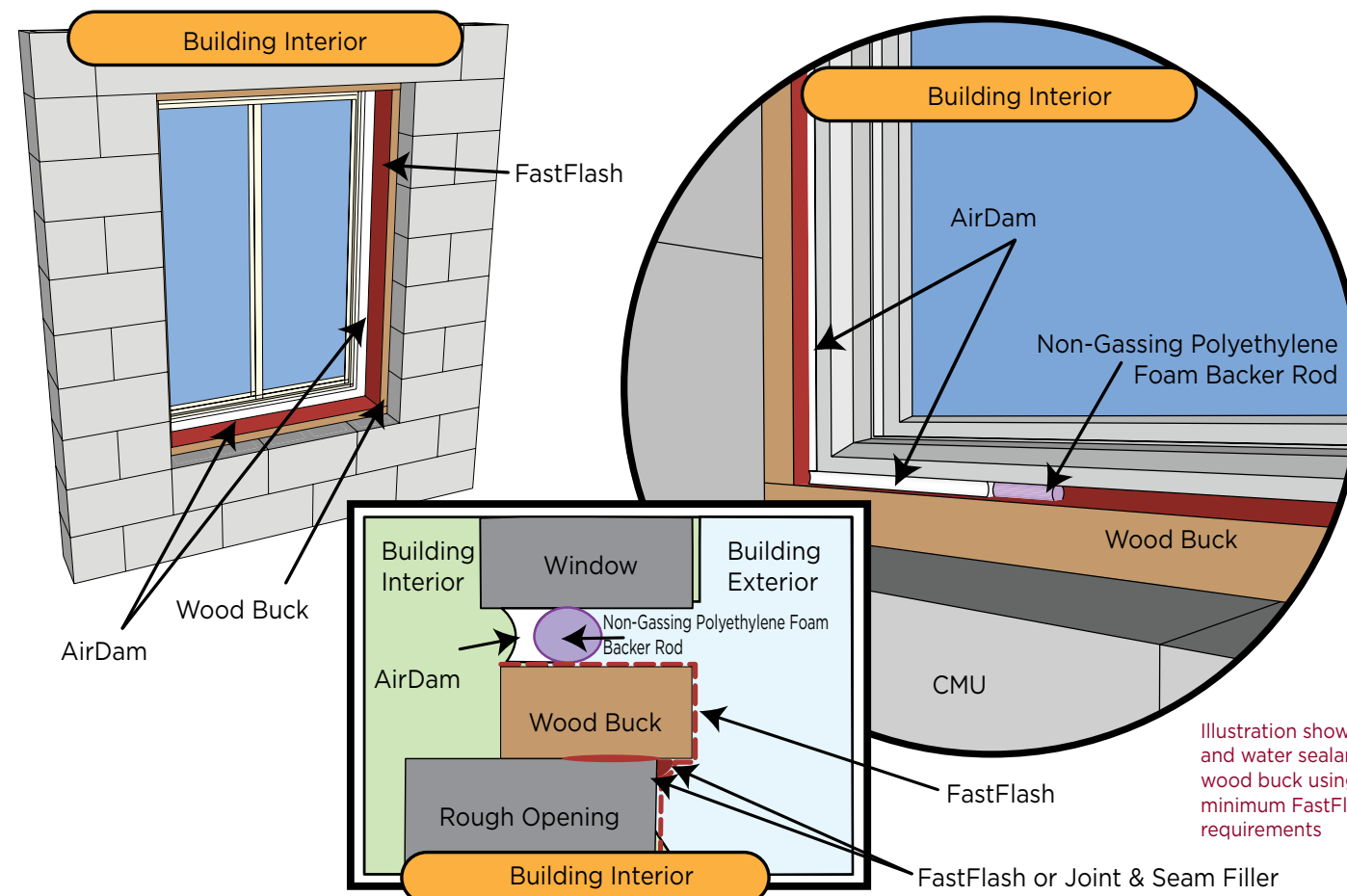

Illustration shows air and water sealant on wood buck using the minimum FastFlash requirements

R-Guard

Sliding Glass Door - C6.1

AIR & WATER BARRIERS

CMU/Cast-in-Place Concrete Wall Construction

Apply a thick bead of **FastFlash** or **Joint & Seam Filler** in each corner and in a zigzag pattern over the inside the concrete block rough opening. Use a dry spatula, trowel or chipper brush to spread the wet product to protect the rough opening CMU surface. Apply additional **FastFlash** or **Joint & Seam Filler** as needed to create an opaque, monolithic flashing membrane free of voids or pinholes. Allow membrane to skin over.

If wood bucks are not already installed, apply two (2) thick beads of **FastFlash** or **Joint & Seam Filler** along the perimeter faces of the wood bucks before attaching to the structure while still wet. Install anchor bolts to secure the wood bucks into the opening. Tapcons/anchor holes should be pre-drilled and blown out with oil-free air in preparation to receive a shot of **FastFlash** or **Joint & Seam Filler** into the hole prior to inserting tapcon/anchor.

After installation of wood buck, spot and cover the installed head of the anchor bolts.

Apply a thick bead of **FastFlash** or **Joint & Seam Filler** to the perimeter joint between the wood buck and CMU wall. Use a dry spatula or trowel to seal the joint. Create a profile that directs bulk water away from the joint. Allow **FastFlash** or **Joint & Seam Filler** to skim over. Apply **FastFlash** over the inside of the wood buck, extending the membrane out to the edge of the return opening when used for window protection only. When used in conjunction w/an entire air/moisture barrier system, carry the **FastFlash** out on to the face of the vertical wall 4-6 inches to facilitate a tie in to an air barrier system.

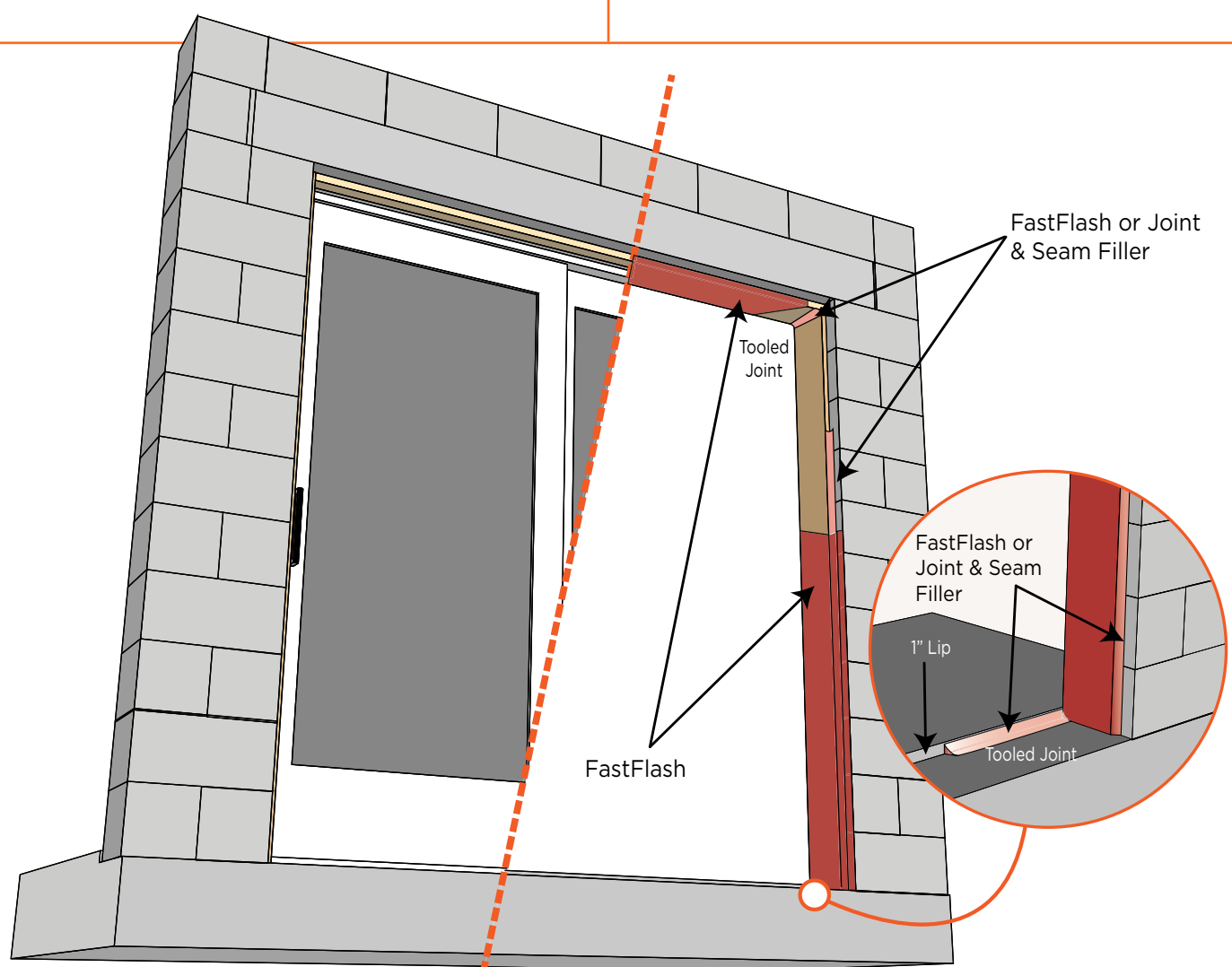

CUSTOMER CARE 800 255 4255 // PROSOCO.COM

R-Guard

Flashing Corner Units and End Dams - F1.1

AIR & WATER BARRIERS

SS ThruWall Flashing

Creating an end dam

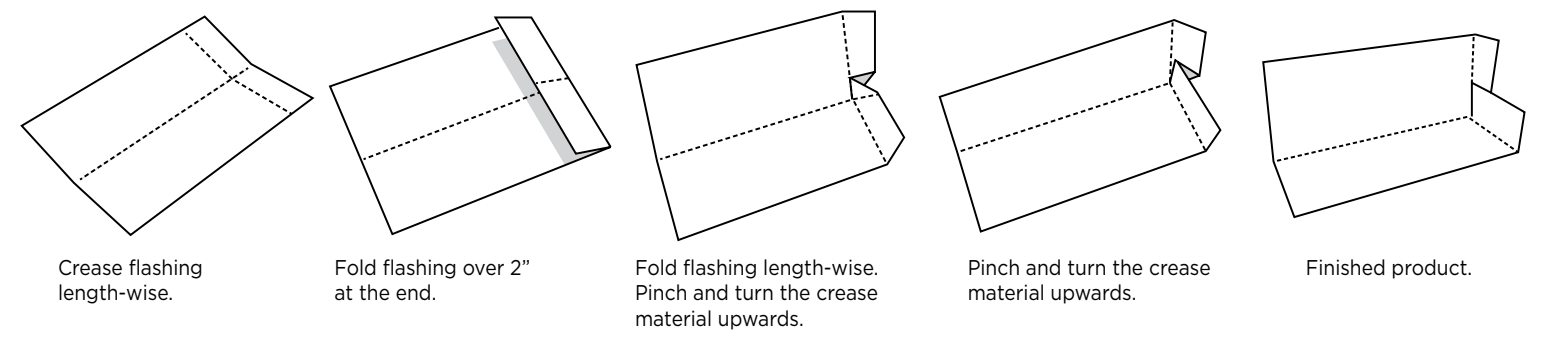

Creating an inside corner

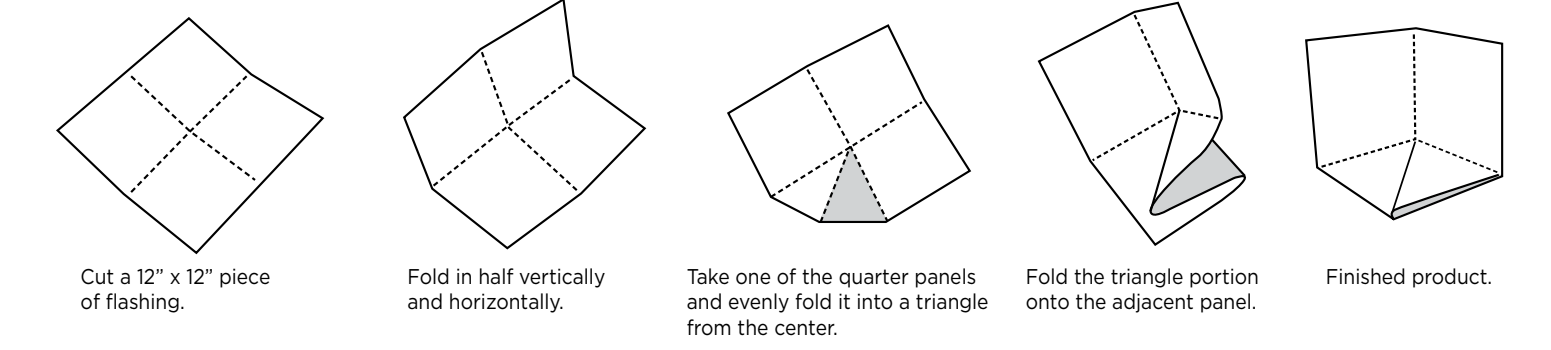

Creating an outside corner

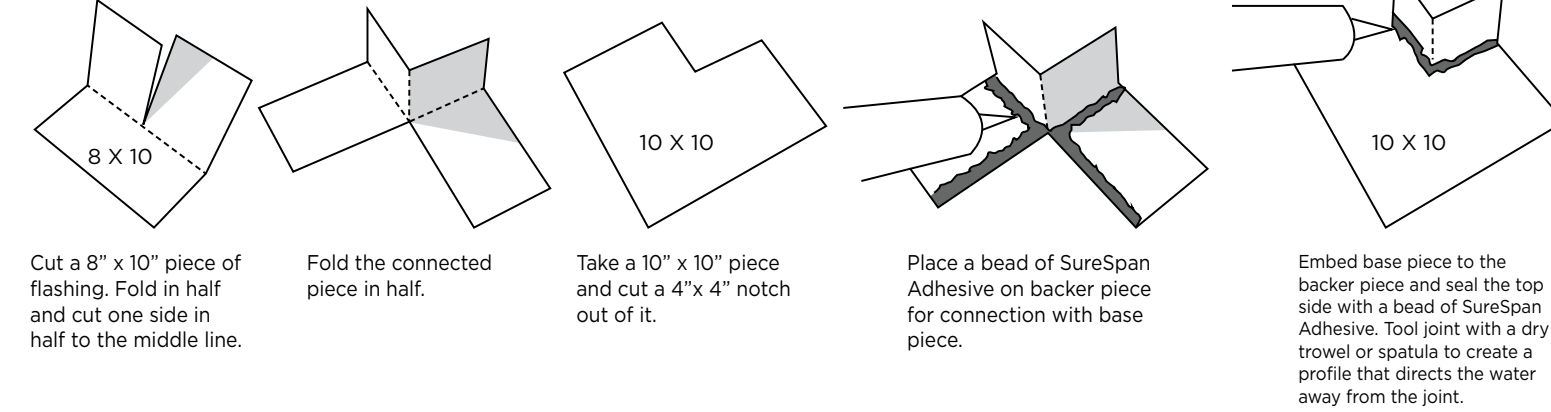

Creating interlocking lap joints

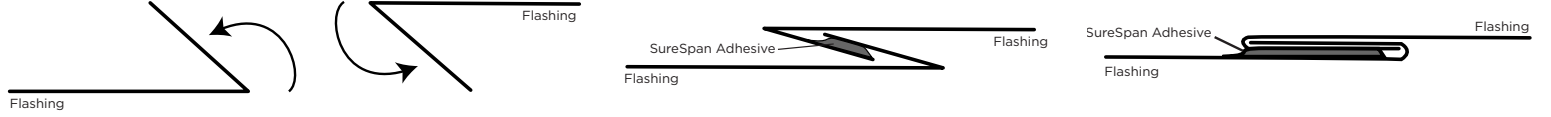

©PROSOCO 122120

CUSTOMER CARE 800 255 4255 // PROSOCO.COM

SS ThruWall Flashing

Install the preformed outside corner by applying generous beads of **FastFlash** on to cast-in-place (CIP) haunch footer. Set the preformed outside corner into wet **FastFlash** to secure to the CIP structure.

Prior to installation of **SS ThruWall** flashing, install generous beads of **FastFlash** on the horizontal ledge of the CIP footer and over the preformed corner to secure the flashing to the structure. At the outside corner overlap condition of **SS ThruWall**, remove the vertical folded sheet area to accommodate the placement installation and sealant bead detailing to seal the interface between the flashing sheets and preformed corner.

Install **SS ThruWall** onto the CIP haunch footer by wet-setting flashing into the **FastFlash**. In order for the flashing to be adequately bonded to the structure, roll over the flashing to set into wet **FastFlash** beads with a laminate roller.

Seal vertical/horizontal edges with a bead of **FastFlash**. Tool joint interface smooth.

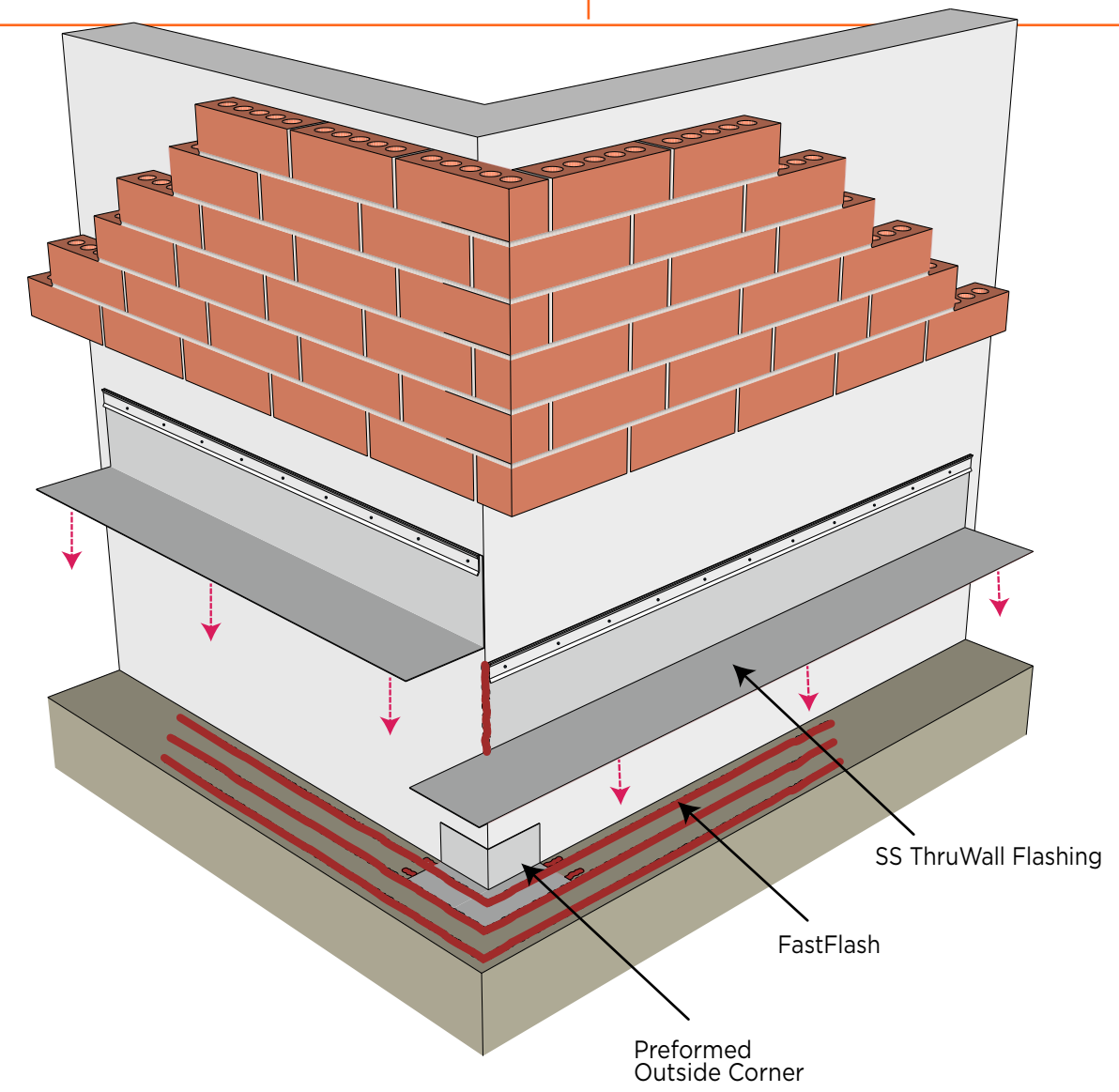

SS ThruWall Flashing

Install the preformed inside corner by applying generous beads of **FastFlash** on to cast-in-place (CIP) haunch footer. Set the preformed inside corner into wet **FastFlash** to secure to the CIP structure.

Prior to installation of **SS ThruWall** flashing, install generous beads of **FastFlash** on the horizontal ledge of the CIP footer and over the preformed corner to secure the flashing to the structure. At the inside corner overlap condition of **SS ThruWall**, remove the horizontal folded sheet area to accommodate the placement installation and sealant bead detailing to seal the interface between the flashing sheets at the preformed corner conditions.

Install **SS ThruWall** on to the CIP haunch footer by wet-setting flashing into the **FastFlash**. In order for the flashing to be adequately bonded to the structure, roll over the flashing to set into the wet **FastFlash** beads with a laminate roller.

Seal vertical/horizontal edges with a bead of **FastFlash**. Tool joint smooth.

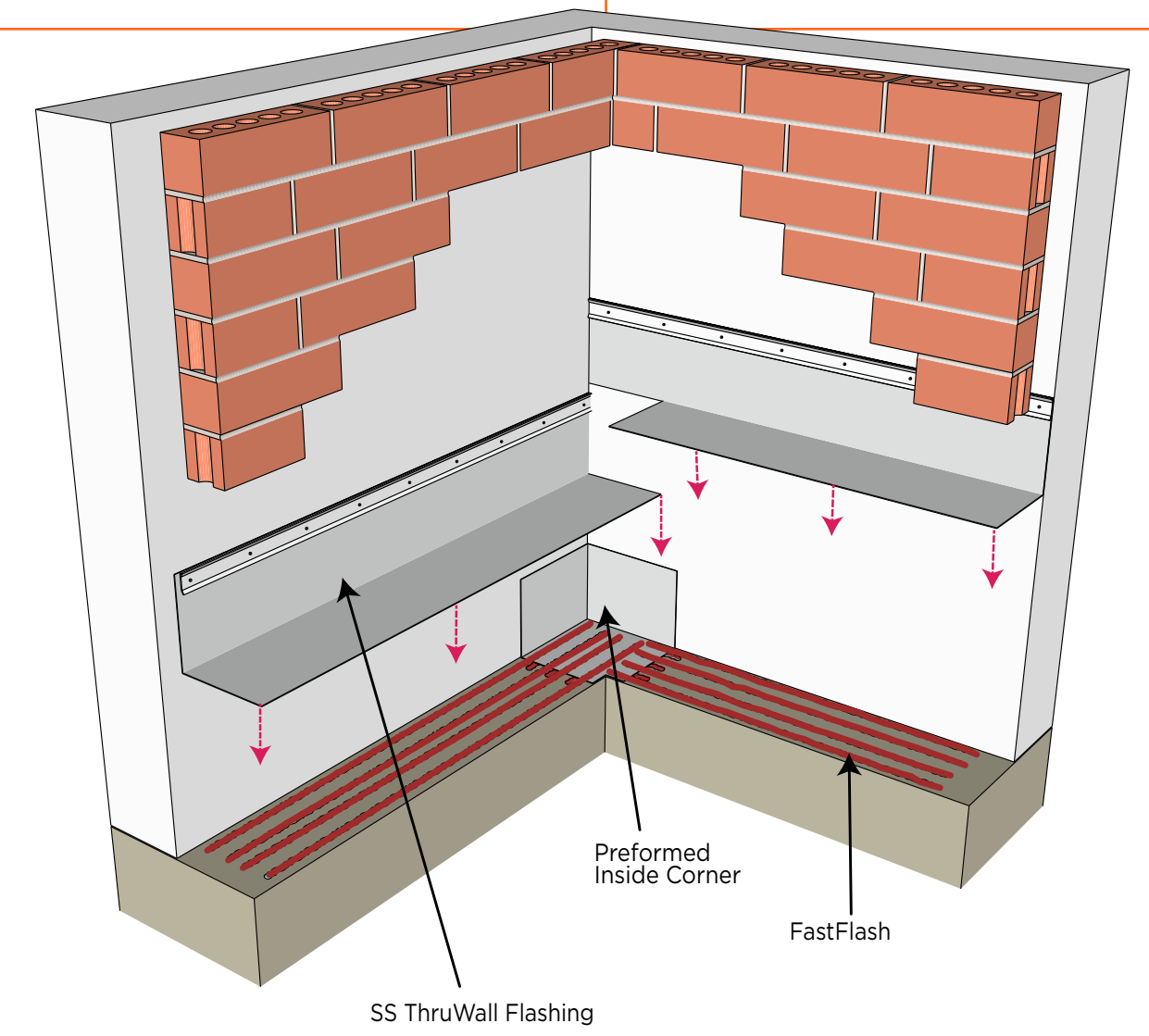

SS ThruWall Flashing

R-Guard's prefabricated stainless steel end dams, inside corners, and outside corners are recommended with all of R-Guard's flashing products. Made of 26 gauge 304 stainless steel. Spot welded and soldered.

- End Dams: Measure 4" H x 4" D x 4" W
- Inside Corner: Measure 4" H x 6" D x 6" W with a 2" notch
- Outside Corner: 4" H x 6" D x 10" W
- Termination Bar: 1" W x 8' L with top sealant lip, 1/4" holes every 8" *(24 gauge)
- Drip Edge: 3" W x 8' L, x 1/4" 30 degree hemmed outside edge
- Corners: inside and outside with hemmed outside edges
- Stainless steel weep vents 2.5 x 3.5, 3.5 x 3.5

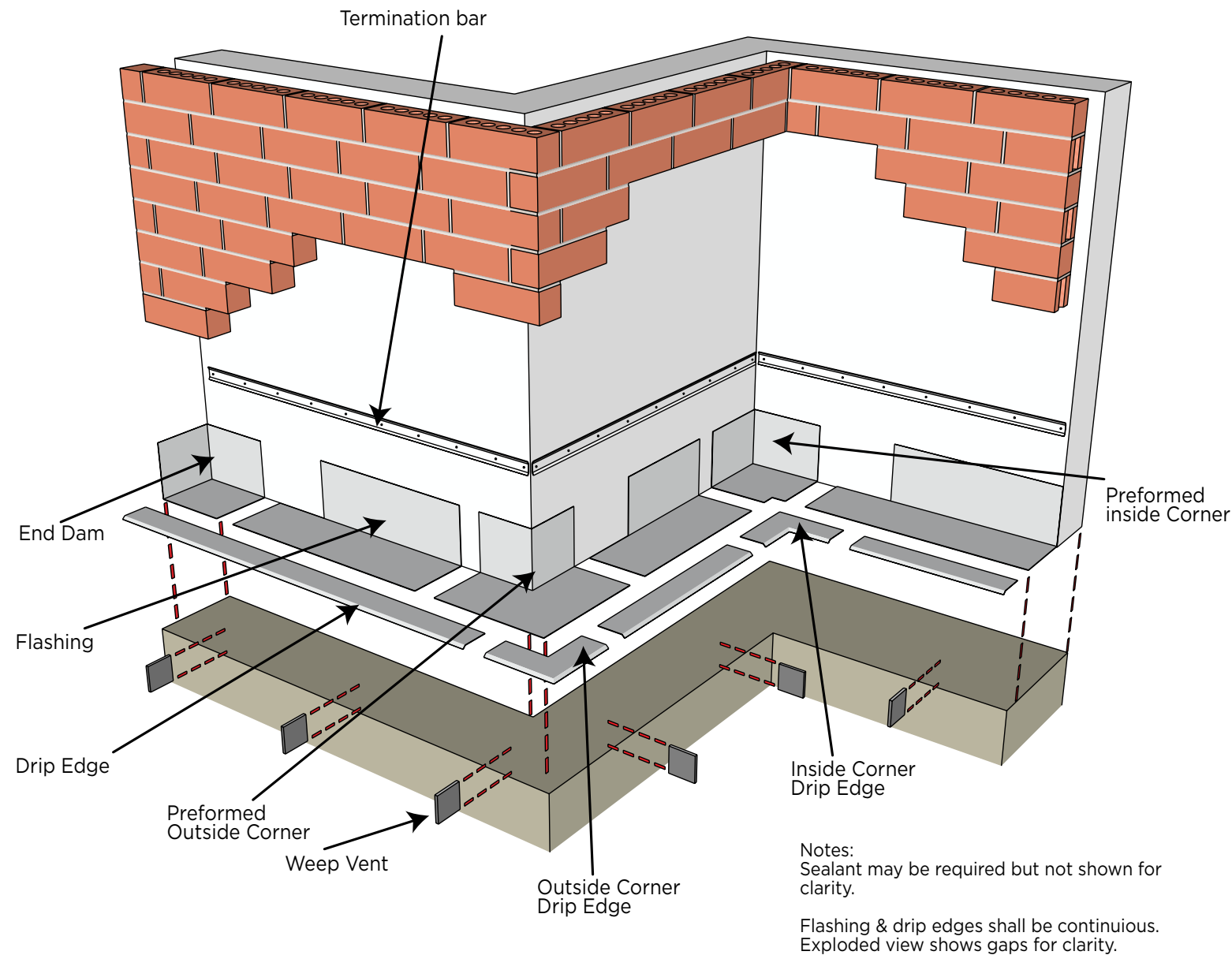

SS ThruWall Flashing

Apply a thick bead of **FastFlash** to the joint between the base of the wall and the foundation. Use a dry trowel or spatula to tool and seal the joint. Create a profile that directs bulk water away from the joint.

Apply a bead of **FastFlash** along the top of the upper vertical edge of the **SS ThruWall** flashing. Wet-set the termination bar. Mechanically fasten the termination bar.

Trade sequencing may make wet-setting impractical, and it is not required.

Apply a bead of **FastFlash** to the top edge of the termination bar. Use a dry trowel or spatula to tool and seal the joint. Create a profile that directs bulk water away from the joint. Allow product to skin over.

To transition from the air- and water-resistive barrier to the **SS ThruWall** flashing, apply a bead of **FastFlash** immediately above and below the top edge of the termination bar. Use a dry joint knife or trowel to spread the wet product to create a seamless counter-flashing membrane which directs bulk water from the air- and water-resistive barrier to the **SS ThruWall** flashing. Apply additional **FastFlash** as needed to create an opaque, monolithic flashing membrane free of voids or pinholes.

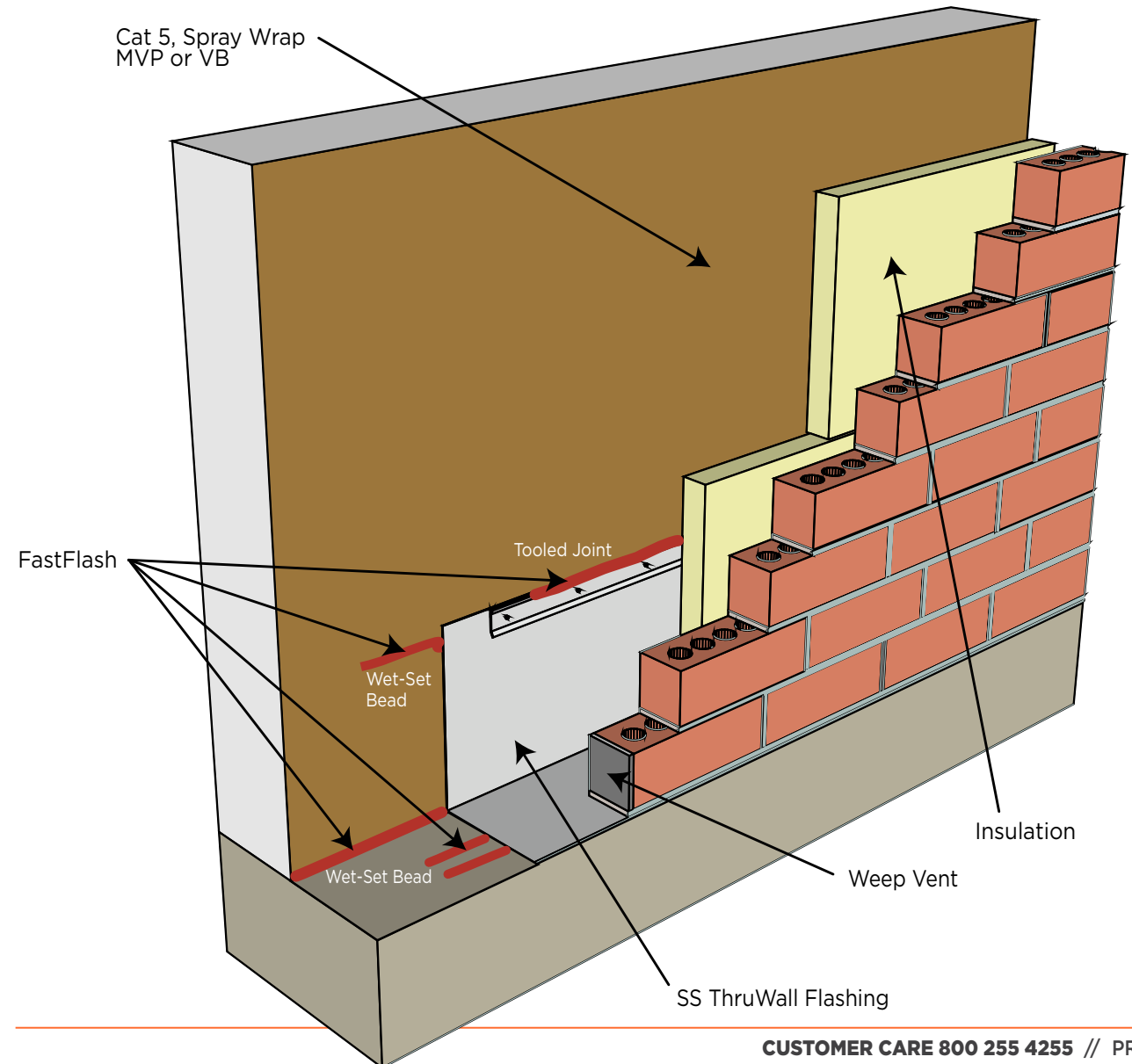

R-Guard

Flashing Transition - Shelf Angle with Termination Bar - F3.1

AIR & WATER BARRIERS

SS ThruWall Flashing

When possible, apply a thick bead of **FastFlash** or **Joint & Seam Filler** to the back of the shelf angle before attaching it to the structure while still wet. Apply a bead to joints between each section of the shelf angle. Tool and seal the joints.

Apply a thick bead of **FastFlash** or **Joint & Seam Filler** to the joint between the shelf angle and the structural wall. Use a dry trowel or spatula to tool and seal the joint. Create a profile that directs bulk water away from the joint. Allow product to skin over.

Use **FastFlash** or **Joint & Seam Filler** to spot and cover the anchor bolts that attach the shelf angle to the structure. Allow product to skin over.

Place drip edge metal on the horizontal lenti/shelf angle. Secure the drip edge to the lenti/shelf angle by wet-setting the edge metal into wet **FastFlash** placed on the horizontal ledge of lenti/shelf angle.

Install **SS ThruWall** flashing.

Apply a bead of **FastFlash** or **Joint & Seam Filler** along the top of the up leg of the **SS ThruWall** flashing. Wet-set the termination bar.

Mechanically fasten the termination bar.

Trade sequencing may make wet-setting impractical, and it is not required.

Apply a bead of **FastFlash** or **Joint & Seam Filler** to the top edge of the termination bar. Use a dry trowel or spatula to tool and seal the joint. Create a profile that directs bulk water away from the joint. Allow product to skin over.

To transition from the air- and water-resistive barrier to the **SS ThruWall** flashing, apply a bead of **FastFlash** immediately above and below the top edge of the termination bar. Use a dry joint knife or trowel to spread the wet product to create a seamless counter-flashing membrane which directs bulk water from the air- and water-resistive barrier to the **SS ThruWall** flashing. Apply additional **FastFlash** as needed to create an opaque, monolithic flashing membrane free of voids or pinholes.

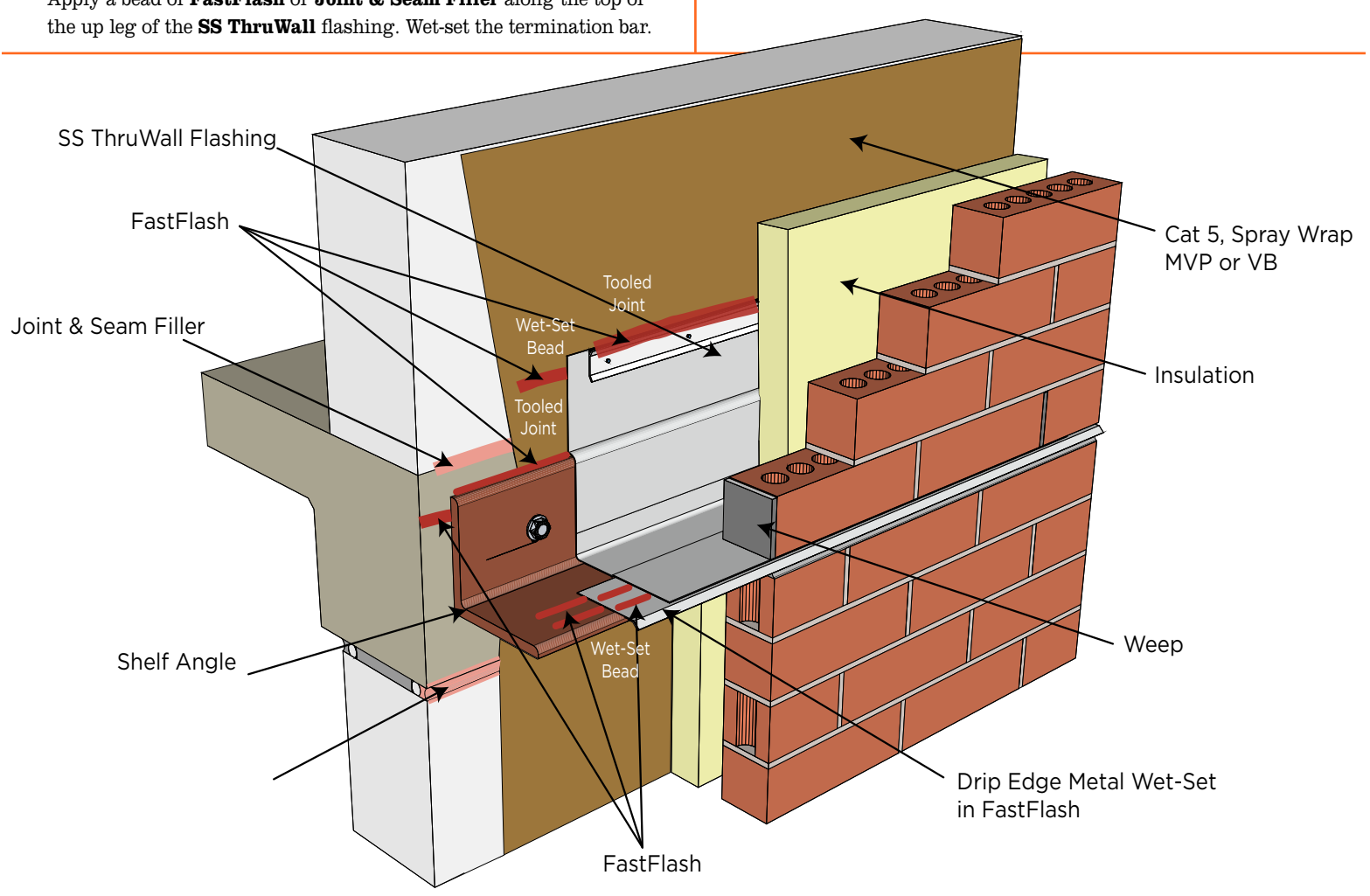

R-Guard

Window Head Detail SS Thru Wall Flashing and Termination Bar- F4.1

AIR & WATER BARRIERS

SS ThruWall Flashing

Place drip edge metal on lenti above the head of the window. Secure the drip edge to the lenti by wet-setting the edge metal into wet **FastFlash** placed on the horizontal ledge of the lenti.

Recess **SS ThruWall** on the horizontal drip edge metal 1/2 inch, then carry up the wall 8 inches above to the supporting wall with **SS ThruWall** over a chamfered cut edge of the insulation as indicated below. Extend flashing 6 inches beyond each side of the masonry opening. Wet-set **SS ThruWall** into **FastFlash** to adhere to the angle and vertical wall interface. Place vertical edge of **SS ThruWall** into a bead of wet **FastFlash** securing the termination bar with fasteners at designated increments (8" or 16" o.c.).

To transition from the air- and water-resistive barrier to the **SS ThruWall** flashing, apply a bead of **FastFlash** immediately above the top edge of the termination bar. Use a dry joint knife or trowel to spread the wet product to create a seamless counter-flashing membrane which directs bulk water from the air- and water-resistive barrier to the **SS ThruWall** flashing. Apply additional **FastFlash** as needed to create an opaque, monolithic flashing membrane free of voids or pinholes.

Place end dam corners at either side of the lenti and seal edges with **FastFlash** creating a pan above the window head. Insert weep vent at the head joints to facilitate evacuation of moisture in the cavity.

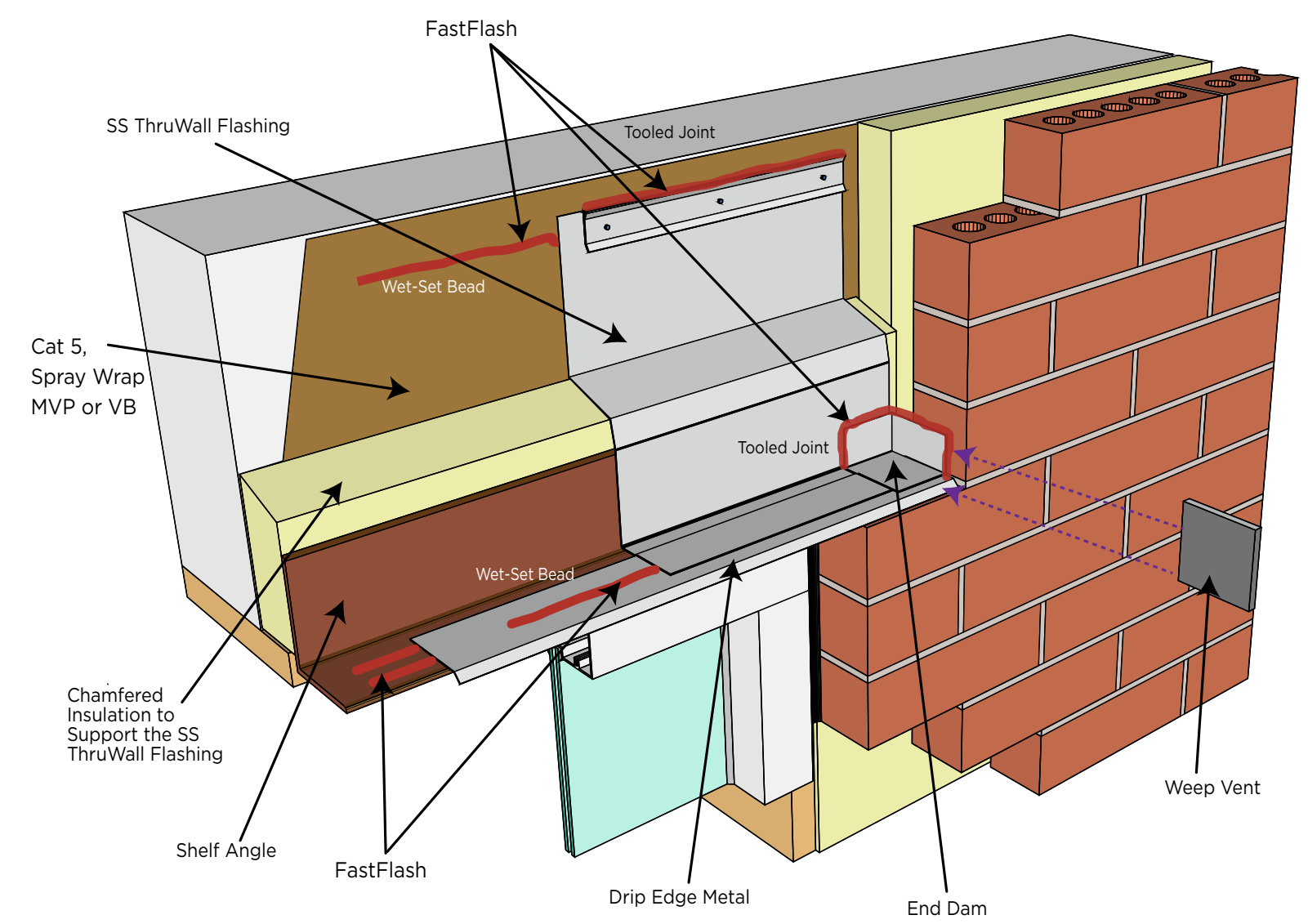



R·Guard[®]

AIR & WATER BARRIERS

Installation Guidelines

800 255 4255 | PROSOCO.COM